

BOXER BM 100



BOXER BM 100

Bajaj Auto Limited
Akurdi Pune 411 035 India
Tel +91 20 27472851
Fax +91 20 27407385
www.bajajauto.com

Provisional Spare Parts Catalogue (Export)



Notice

BOXER BM 100

All information contained in this manual is based on the latest product information at the time of publication. Bajaj Auto Limited accepts no liability for any inaccuracies or omissions in this publication, although every possible care has been taken to make it as complete and accurate as possible. All procedures and specifications subject to change without prior notice. The right is reserved to make such changes at any time without prior notice and without incurring an obligation to make such changes to product manufactured previously. Contact your authorized Bajaj Dealer for the latest information on product improvements incorporated after this manual was issued.

DOC. NO.: 71111490

REV. 00, SEPT. 11

We have pleasure in presenting the Spare Parts Catalogue for 'Boxer BM 100 (ES / KS)' Motorcycle. This catalogue has been specially designed to assist you in selecting the correct parts for procurement to maintain 100% availability.

The Bajaj spares are subjected to the stringent quality control standards to ensure longer life of the vehicle. It is therefore necessary that only the Genuine Bajaj Spares are used.

In a continual effort to improve Performance and Efficiency of the vehicles, Specifications, Diagrams, Illustrations and Part Numbers can change without notice. Consequently, the description in this Spare Parts Catalogue cannot therefore be final and binding on us.

The modifications / alterations which are carried out after the issue of this catalogue, will be conveyed to you through our Service Circulars. You are requested to make necessary corrections in the Parts Catalogue as per the circulars so as to keep your catalogue up-to-date. This will ensure the appropriate and speedy delivery of the Spare Parts as the order placed will bear the latest part numbers.

In case, if you need any technical assistance contact the concerned Regional Office or write to us on the following address :

Bajaj Auto Limited
Technical Service Department (International Business)
Akurdi, Pune 411 035 India
Phone : 020-27472851
Fax : 020-27407395
E-mail : exports@bajajauto.co.in

1. How to Read the Catalogue : Open the catalogue and from the pictorial index locate the group in which the part you want to find is present. Turn over to the concerned page number (as given by pictorial index). Now find out the figure of the part you wish to order. Write down the part number against that particular figure number from the text.

In case, if you have the part number and you need the other details, the part index can be used. The part index (at the end of the catalogue) will give you the figure and page number of the part you wish to order.

2. How to Order Spare Parts : The part number and the description of the part required should be invariably mentioned in the order as per the catalogue text.

The latest part number as conveyed through our service circulars should only appear on the order. In case of ordering painted components, colour shade of the components should be mentioned.

The quantity shown against the part number is the quantity per vehicle for that group so that particular quantity should be multiplied by the number of sets required.

3. Part Number System : We have used 8 digit system for part numbers. The model or hardware item is indicated by first two digits or alphanumeric, the next two or four digits indicate main group and the last four or two digits indicate serial number in main group or serial number or subgroup of fastener respectively. Thus the part numbers will be indicated by 2-2-4 or 2-4-2 digit system. Understanding this system will enable you to identify the spare parts easily.

4. Abbreviations : The following abbreviations are used in this catalogue.

Assly	Assembly	V	Volts
N.I.	Not illustrated	W	Watts
C'case	Crankcase	Accl.	Accelerator
Cyl	Cylinder	Comp.	Complete
O/s	Over size	Fr.	Front
Rr.	Rear	Std.	Standard
L	Length	A/t.	Alternate
R.H.	Right hand	L.H.	Left hand
Hex.	Hexagonal	AR	As required

Index

BOXER BM 100

Plate No.	Description	Page No.
1	Cover Cylinder Head	2
2	Cylinder Head	4
3	Valve	6
4	Camshaft / Tensioner	8
5	Cylinder & Piston	10
6	Crankshaft	12
7	Transmission	14
8	Change Drum / Shift Fork	16
9	Gear Change Mechanism	18
10	Crankcase RH	20
11	Crankcase LH	22
12	Clutch Cover	24
13	Cover Magneto	26
14	Clutch Assembly	28
15	Kick Starter Mechanism	30
16	Carburettor	32
17	Air Cleaner Complete	34
18	Silencer Assly	36
19	Oil Pump	38
20	Starter Assembly	40
21	Magneto / C.D.I. / H.T. Coil	42
22	Frame & Frame Fitting	44
23	Swing Arm / Rear Shock Absorber	46
24	Fender - Front & Rear	48
25	Foot Rest / Holder / Stand	50
26	Wheel Rim/ Spoke / Tyre / Tube	52
27	Front Hub	54

Index

BOXER BM 100

Plate No.	Description	Page No.
28	Rear Hub	56
29	Brake Pedal	58
30	Handle Bar	60
31	Front Fork	62
32	Painted Parts	64
33	Fittings - Petrol Tank, Side Covers & Cover Seat	66
34	Petrol Tank, Cap Tank and Gauge Fuel	68
35	Side Covers Fitment	70
36	Chain Case	72
37	Meter Assly	74
38	Head Lamp Assly	76
39	Control Cable	78
40	Turn Signal Lamp	80
41	Tail Lamp Assly & Number Plate	82
42	Seat Assly & Grip Frame	84
43	Electrics Equipments	86
44	Tool Kit	88
45	Accessories	90

Cover Cylinder Head

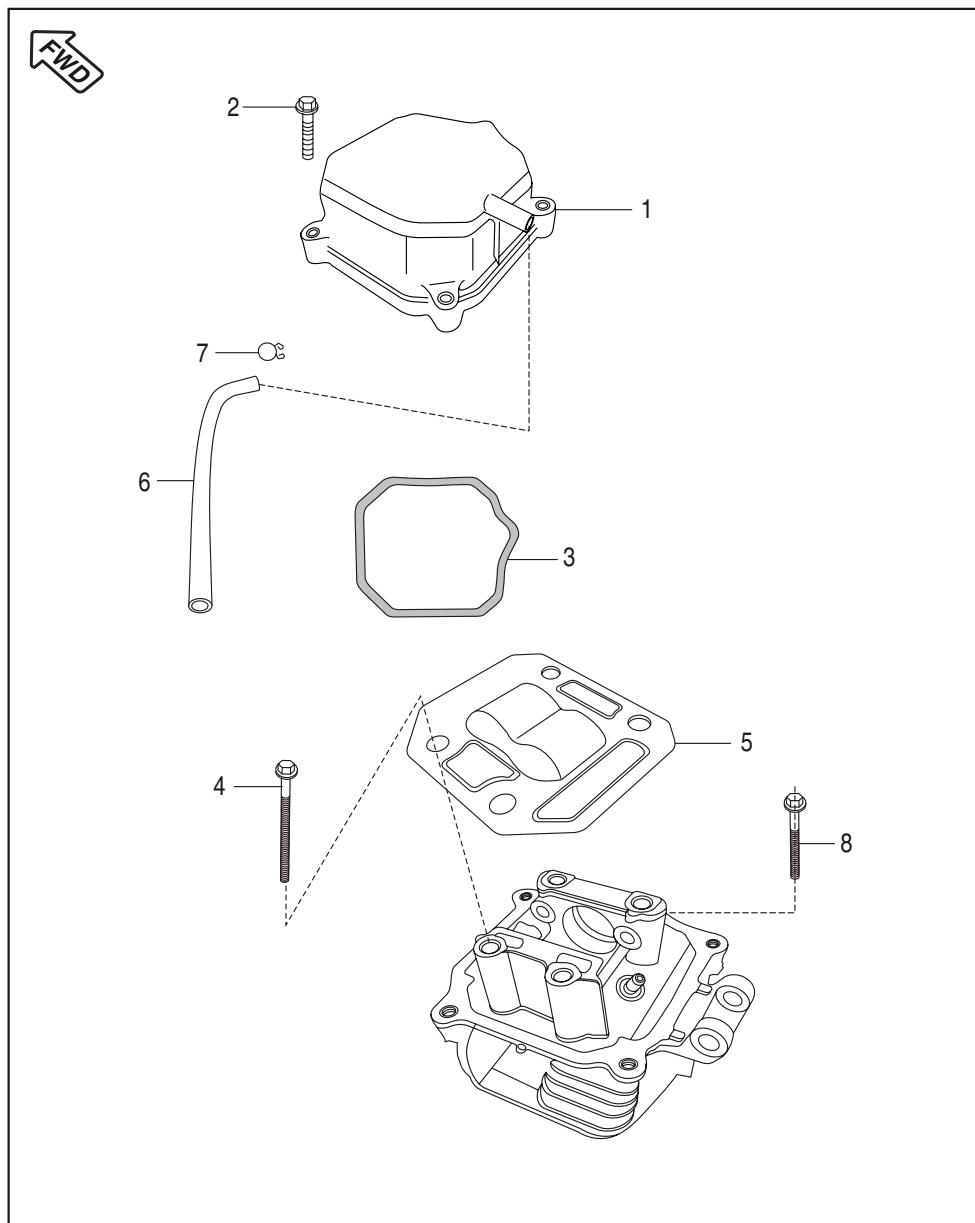

No.	Part No.	Description	Qty		Remarks
			KS	ES	
1	JZ 5110 21	Cover Cylinder Head Assly	1	1	
2	JV 5410 07	Bolt Flange	4	4	
3	JD 5110 10	Gasket Head Cover	1	1	
4	JB 5110 11	Bolt Head Mounting	4	4	M8 X 1.25 X 190L
5	JZ 5110 20	Plate Cylinder Head	1	1	
6	JA 5110 11	Hose Breather	1	1	
7	DP 1210 25	Clamp (ID 12.5 MM)	3	3	
8	JB 5110 15	Flange Bolt	1	1	

Cylinder Head

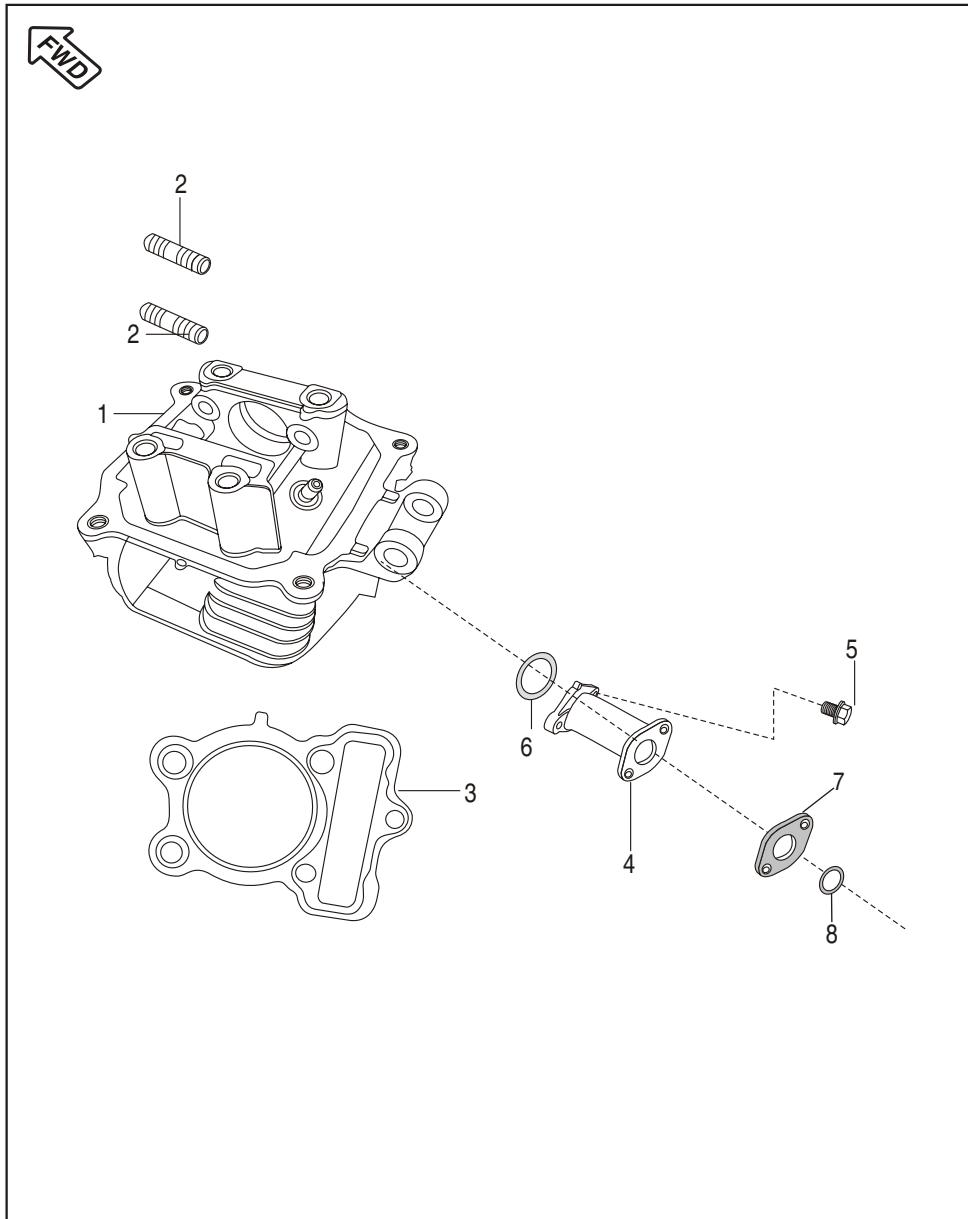

No.	Part No.	Description	Qty		Remarks
			KS	ES	
1	36 PF00 37	Kit Assly. Cylinder Head	1	1	Ref. Page No.
2	JA 5110 28	Stud	2	2	M8 X 25 Silver
3	JB 5110 19	Gasket Cylinder Head	1	1	
4	PF 5814 00	Intake Manifold	1	1	
5	JA 5814 06	Bolt Flange	2	2	
6	39 1283 21	'O' Ring (Intake Pipe)	1	1	
7	JB 5812 71	Insulator PTE-16	1	1	
8	JB 5812 72	'O' Ring Insulator	1	1	

Valve

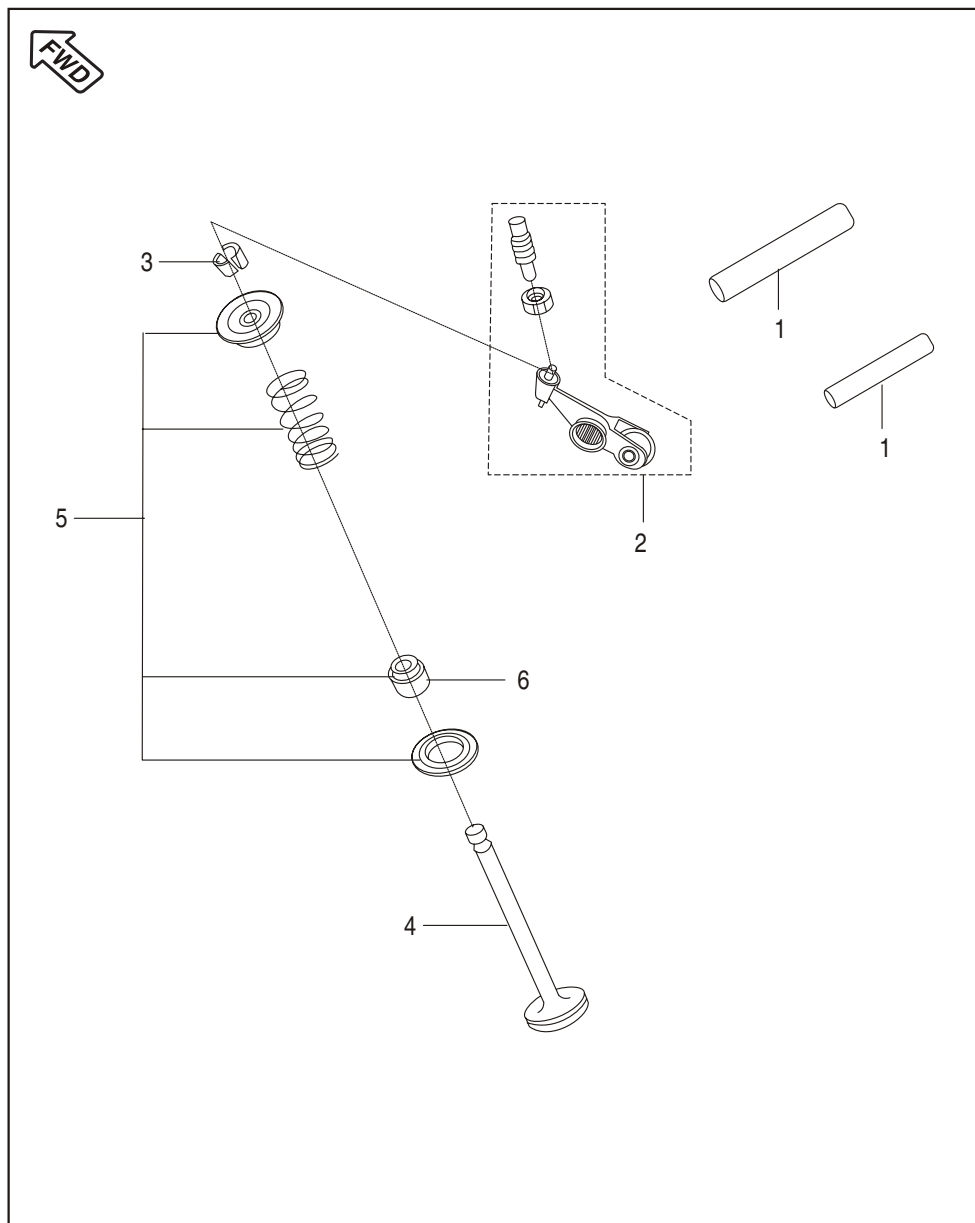

No.	Part No.	Description	Qty		Remarks
			KS	ES	
1	JA 5112 11	Shaft Rocker Arm	2	2	48.2 mm
2	JA 5112 04	Rocker Arm with Roller	2	2	
3	DG 1010 29	Cotter Valve (Collet)	4	4	
4	36 PA00 04	Valve Kit	1	1	Refer Page No. 92
5	36 JA00 03	Valve Repair Kit	1	1	Refer Page No. 91
6	39 2017 19	Seal Valve Stem	2	2	

Camshaft / Tensioner

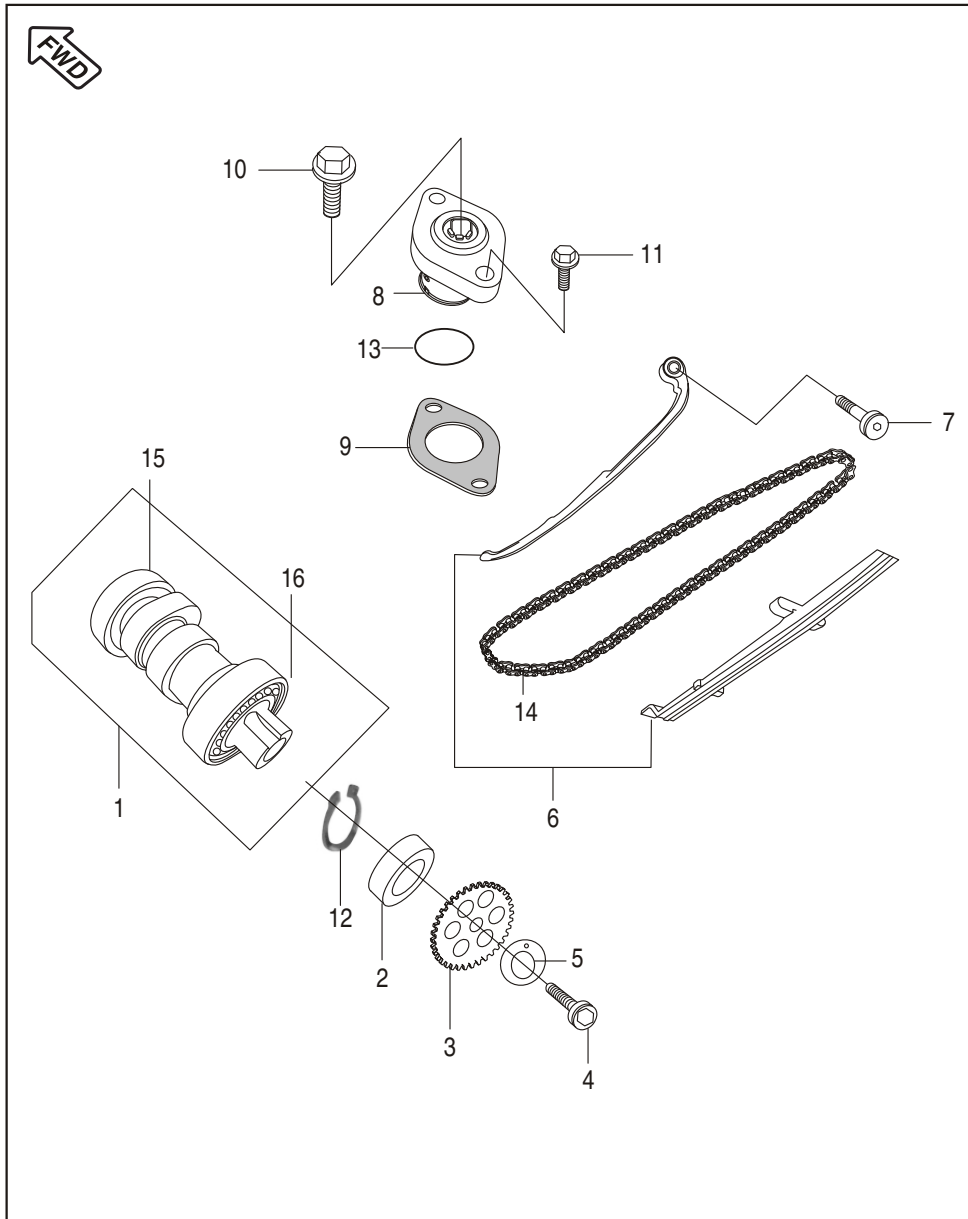

No.	Part No.	Description	Qty		Remarks
			KS	ES	
1	PF 5112 00	Assly. Camshaft Complete	1	1	
2	JA 5112 16	Spacer Cam Sprocket	1	1	
3	DS 1012 76	Sprocket Cam Shaft - 32 T	1	1	
4	DH 1013 87	Hex Head Bolt	1	1	
5	DH 1010 48	Special Washer Cam Shaft	1	1	'O' Washer
6	36 PA00 02	Guide Chain Kit	1	1	Ref. Page No. 91
7	DH 1013 92	Cam chain Tensioner Pivot Bolt	1	1	
8	JV 5210 03	Adjuster Chain Silver	1	1	
9	CS 1011 28	Gasket	1	1	
10	JA 5210 18	Bolt M6 Chain Tensioner	1	1	
11	JA 5210 19	Bolt M6 X 20 Silver	2	2	Adjuster Mounting
12	39 0594 17	Circlip for Camshaft	1	1	
13	39 2669 21	'O' Ring (Tensioner)	1	1	
14	JA 5310 11	Cam Chain (94 Link)	1	1	
15	39 1988 20	Bearing Ball - Small 12 X 28 X 8	1	1	W X OD X ID
16	39 2683 20	Bearing Ball - Big 17 X 35 X 10	1	1	

Cylinder and Piston

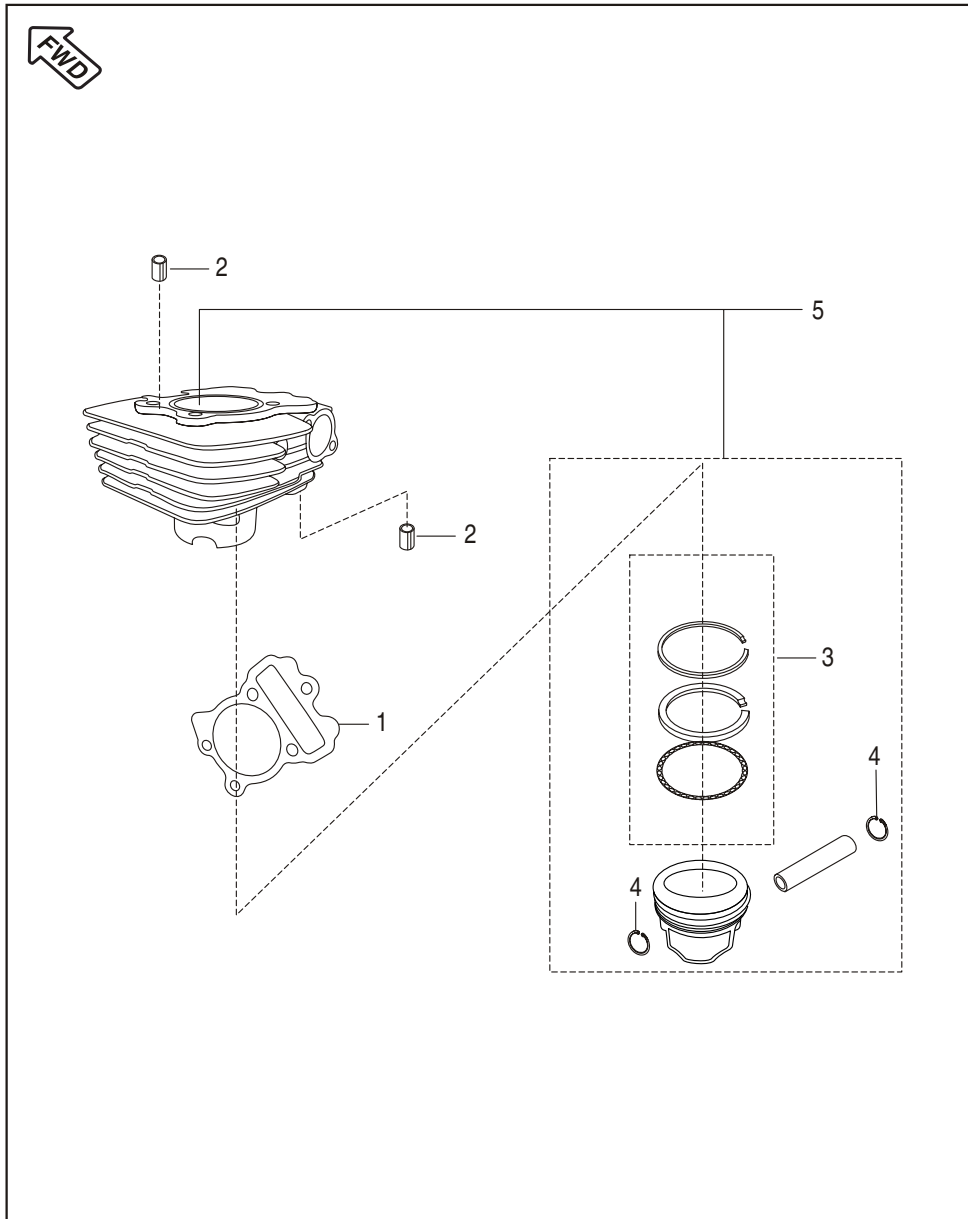

No.	Part No.	Description	Qty		Remarks
			KS	ES	
1	JD 5210 02	Gasket Cylinder Block	1	1	
2	39 1000 06	Dowel Pin	2	2	
3	36 PF00 28	Piston Ring Set	1	1	Refer Page No. 92
4	JB 5212 11	Wire Clip Piston	2	2	
5	36 PF00 27	Kit Cylinder Block / Piston Assly.	1	1	Refer Page No. 92

Crankshaft

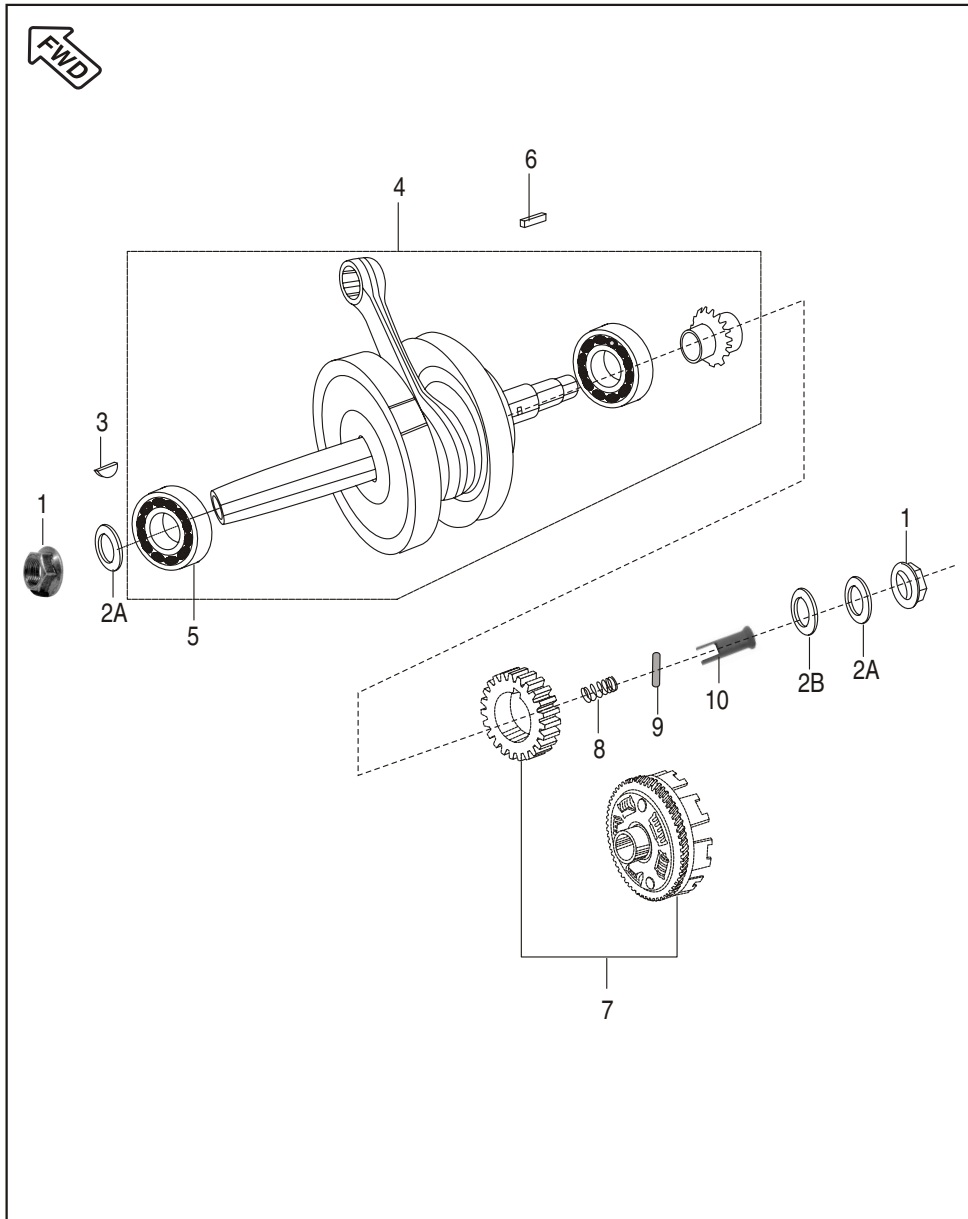

No.	Part No.	Description	Qty		Remarks
			KS	ES	
1	59 1500 14	Flange Nut	2	2	Refer Page No. 91
2A	59 1200 03	Belleville Washer	2	2	
2B	59 1100 08	Plain Washer	1	1	
3	31 1011 73	Key Woodruff	1	1	
4	PF 5310 02	Crank Shaft Assly	1	1	
5	39 1864 20	Ball Bearing 20 X 52 X 15	2	2	
6	DS 1011 54	Parallel Key	1	1	
7	36 JZ00 23	Set Primary Drive / Driven	1	1	
8	JA 5310 12	Spring	1	1	
9	JA 5310 15	Pin Crank Shaft Plunger	1	1	
10	JB 5310 21	Plunger Oil Crank Shaft	1	1	

Transmission

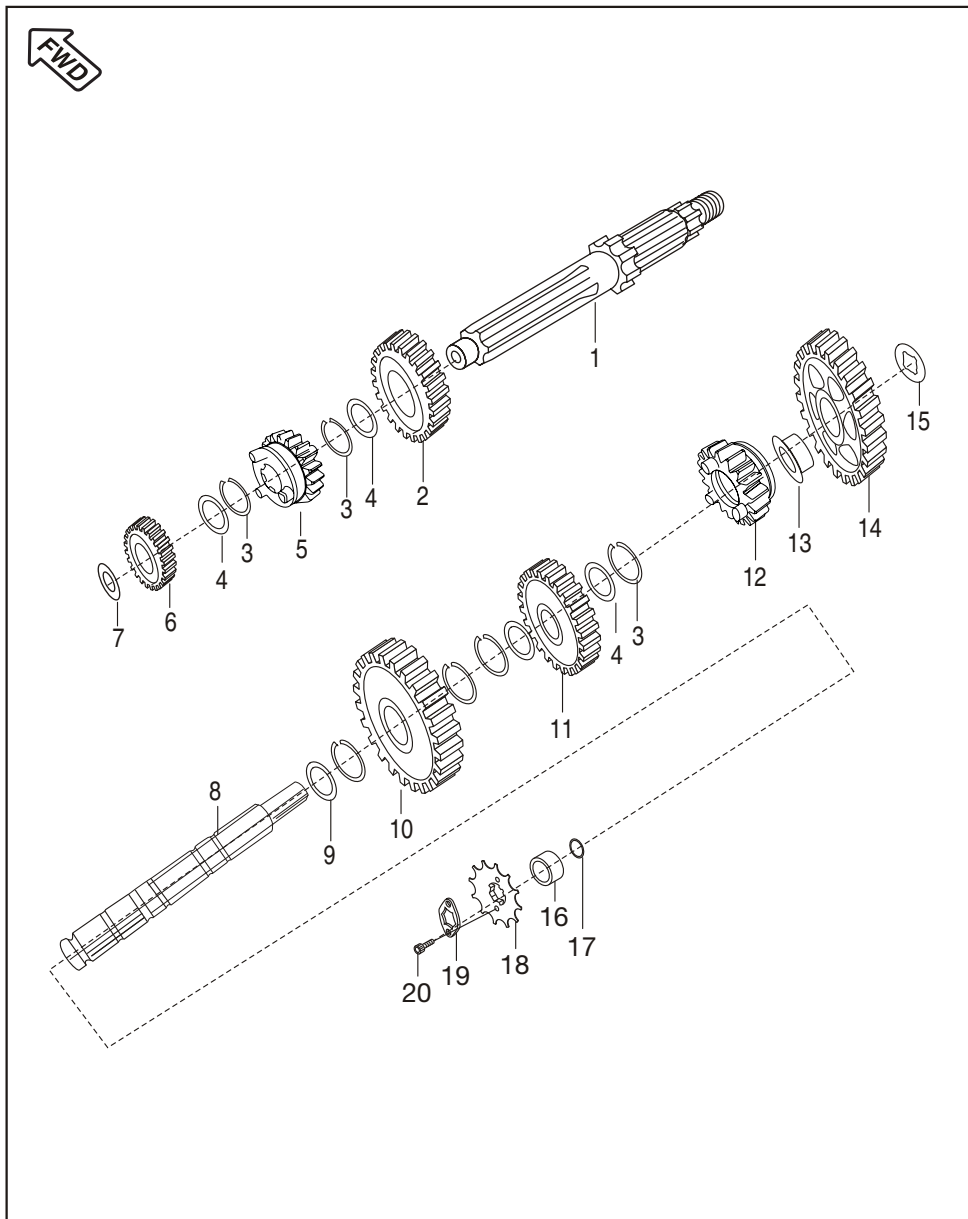

No.	Part No.	Description	Qty		Remarks
			KS	ES	
1	PF 5510 02	Shaft Input Transmission (Drive)	1	1	
2	PF 5512 02	Gear 4th Drive	1	1	
3	39 0987 17	Ring Snap (17.2 X 20.5 X 1.5)	5	5	
4	JA 5510 02	Spline Washer (17.2 X 20.5 X 1.5)	3	3	
5	PF 5512 01	Gear 3rd Drive	1	1	
6	PF 5512 00	Gear 2nd Drive	1	1	
7	JA 5510 04	Washer Thrust 2nd Drive	1	1	
8	PF 5510 03	Shaft Output Transmission (Driven)	1	1	
9	PF 5512 06	2nd Driven Washer	1	1	
10	PF 5512 03	Gear 2nd Driven	1	1	
11	PF 5512 04	Gear 3rd Driven	1	1	
12	PF 5512 05	Gear 4th Driven	1	1	
13	JZ 5512 05	Bush 1st Driven	1	1	
14	JZ 5512 04	Gear 1st Driven	1	1	
15	JA 5510 08	Washer Thrust 1st Driven	1	1	
16	JA 5510 09	Collar Sprocket Drive	1	1	
17	59 2100 24	'O' Ring Collar Sprocket (13.8 X 1.9)	1	1	
18	JZ 5510 04	Sprocket Drive (Engine Sprocket)	1	1	14 Teeth
19	DU 1012 13	Plate Lock Sprocket	1	1	
20	39 1981 04	Socket Head Bolt	2	2	

Change Drum / Shift Fork

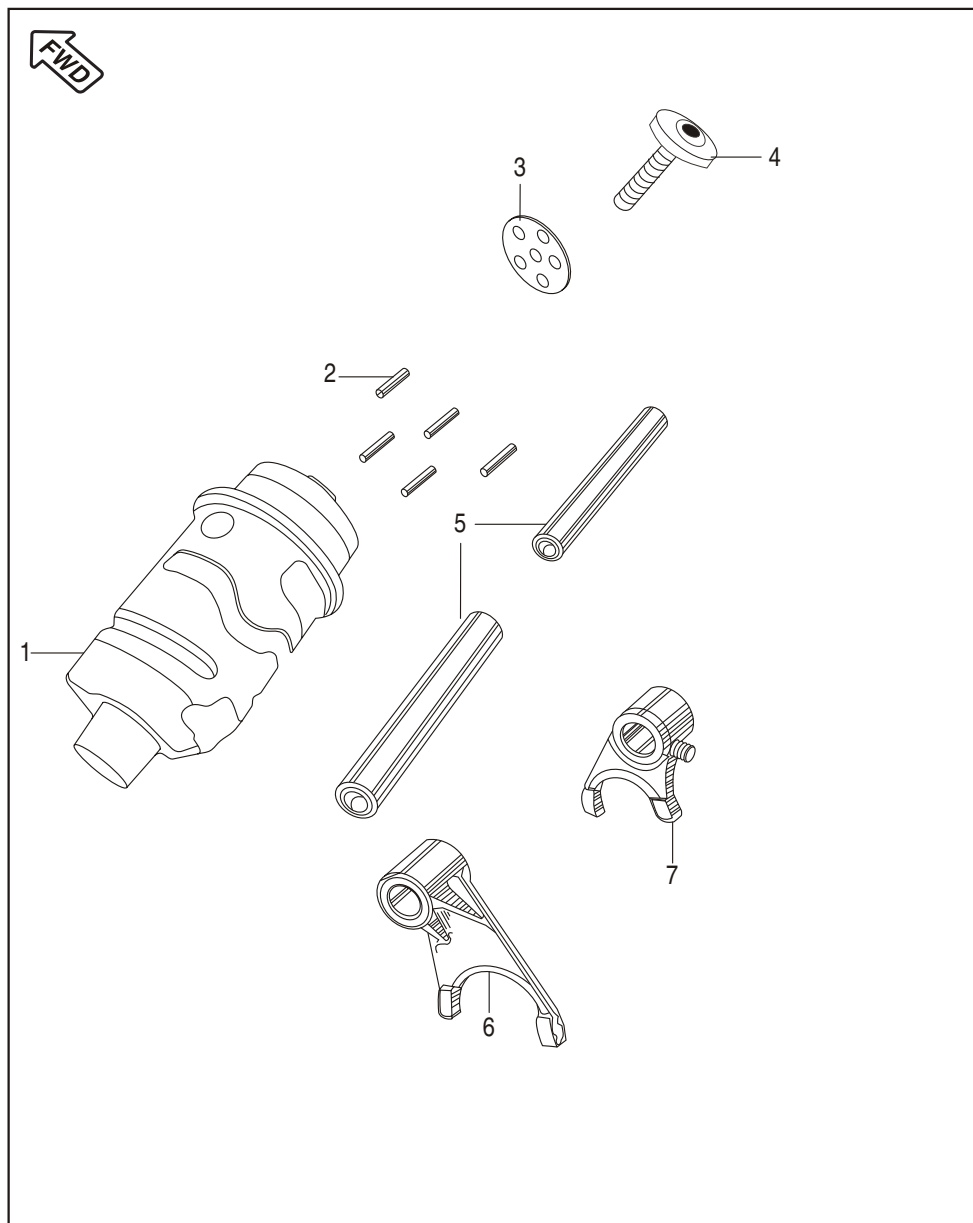

No.	Part No.	Description	Qty		Remarks
			KS	ES	
1	PF 5610 00	Drum Complete Gear Shift	1	1	
2	39 0992 06	Dowel (Pin Drum Change)	5	5	
3	JA 5610 02	Cam Drum Change	1	1	
4	JD 5610 11	Special Bolt Drum Change	1	1	M6 X 1
5	PF 5610 02	Shaft Gear Shift Fork	2	2	
6	JD 5610 04	Fork Gear Shift Output	1	1	
7	JZ 5610 02	Fork Gear Shift Input	1	1	

Gear Change Mechanism

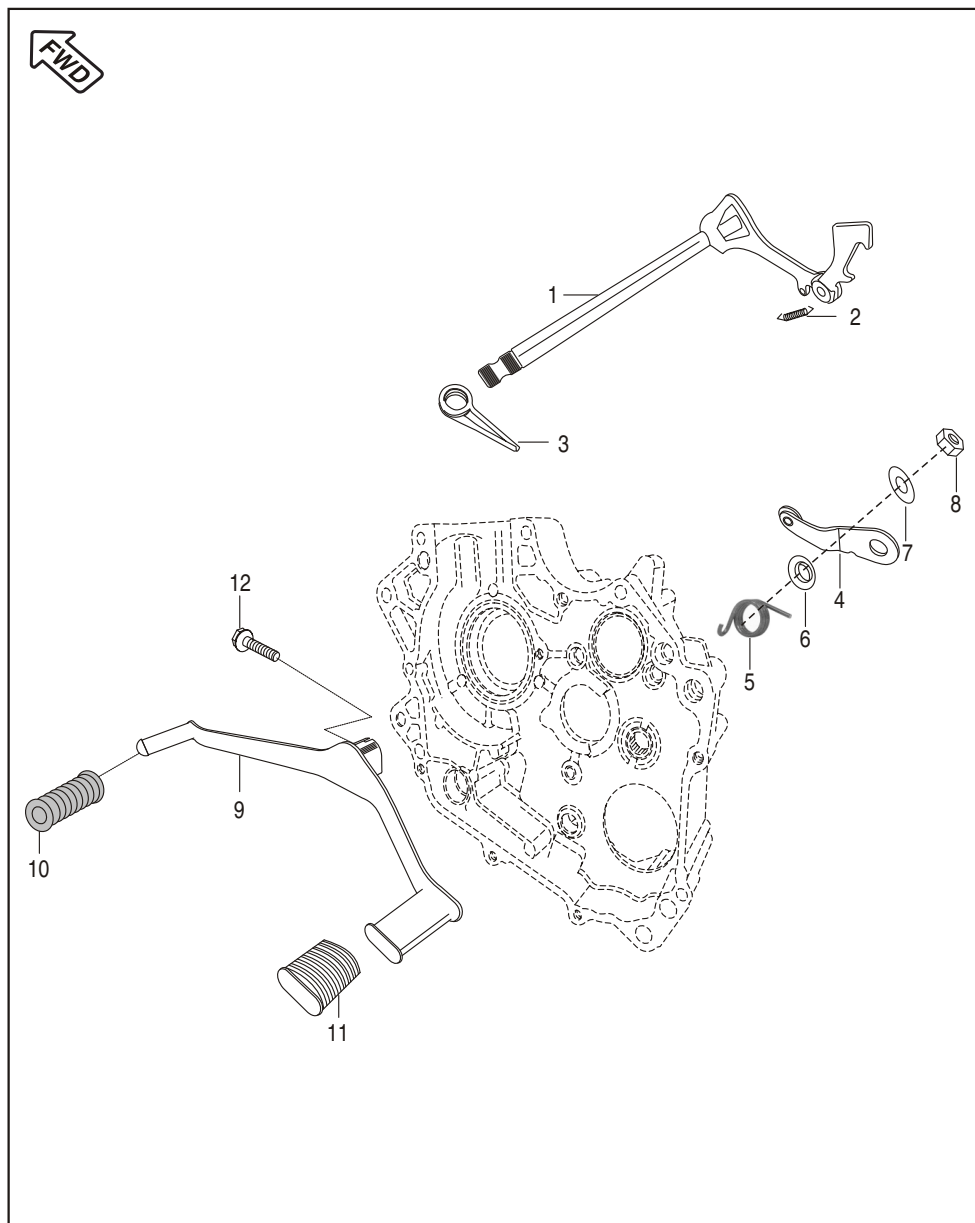

No.	Part No.	Description	Qty		Remarks
			KS	ES	
1	PF 5612 00	Lever Gear Shift Comp	1	1	
2	JW 5612 06	Extension Spring	1	1	
3	JW 5612 08	Spring Gear Shift Return	1	1	
4	JA 5612 07	Inhibitor Complete Gear Shift	1	1	
5	JA 5612 08	Spring Inhibitor	1	1	
6	JA 5612 09	Step Washer (Collar)	1	1	
7	39 2704 11	Plain Washer	1	1	
8	39 0817 15	Hex Nut / Flange - M6	1	1	
9	JZ 5614 01	Lever Gear Shift (Gear Pedal)	1	1	
10	DH 1015 09	Damper	1	1	
11	DG 1013 39	Damper	1	1	
12	JA 5612 11	Flange Bolt	1	1	

Engine Assembly / Crankcase RH

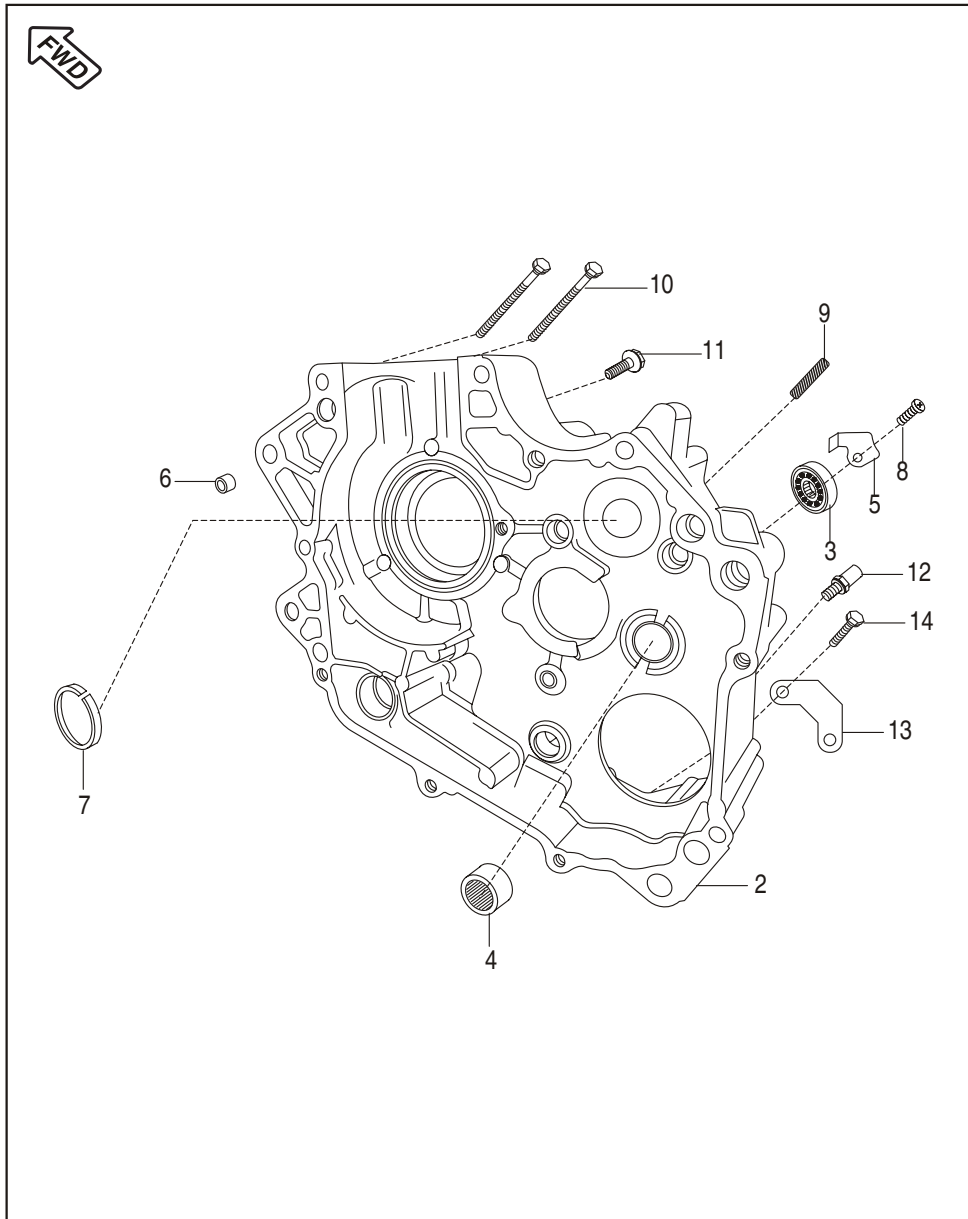

No.	Part No.	Description	Qty		Remarks
			KS	ES	
1	PF 5010 05	Engine Assly ES 4 Speed	--	1	N.I.
	PF 5010 06	Engine Assly KS 4 Speed	1	--	N.I.
2	36 PF00 40	Kit Crankcase RH	1	1	
3	59 2000 36	6203 Ball Bearing	1	1	For I/P Shaft.
4	JA 5410 11	Needle Roller Bearing	1	1	For O/P Shaft.
5	JA 5410 10	Stopper Plate	1	1	
6	39 1000 06	Dowel Pin	2	2	
7	PF 5410 18	Bushing Drum BM-150	1	1	
8	DH 1013 80	Screw	1	1	
9	52 JA00 27	Stud Inhibitor Mounting	1	1	
10	JV 5412 16	Bolt M6 X 85 Silver	2	2	Crankcase Mounting
11	JV 5410 07	Flange Bolt	1	1	Crankcase Mounting
12	52 JA00 29	Bolt Shift Change	1	1	
13	JA 5410 12	Guide Kick	1	1	
14	39 1964 04	Flange Bolt - Small	2	2	

Crankcase LH

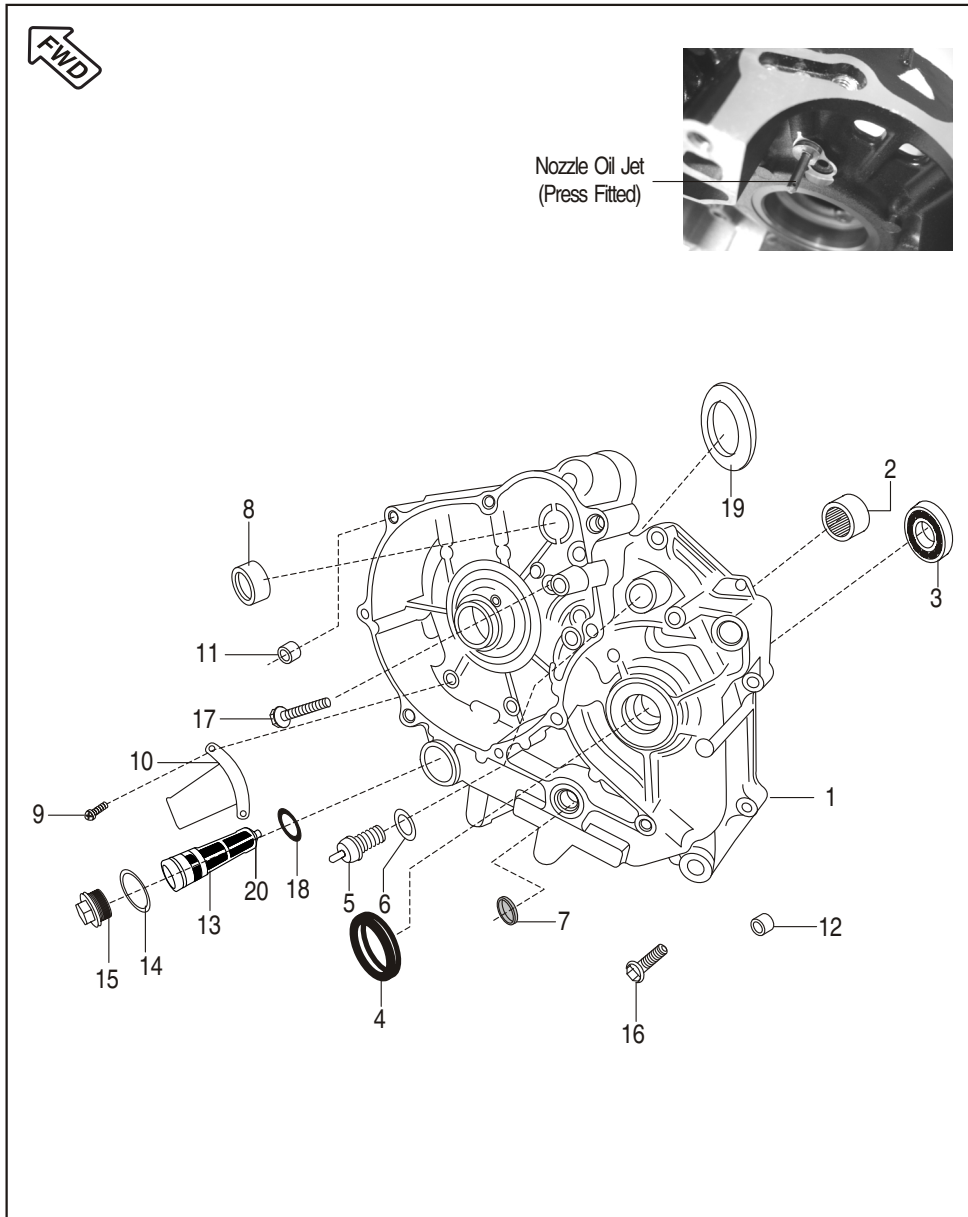

No.	Part No.	Description	Qty		Remarks
			KS	ES	
1	36 PF00 39	Kit Crankcase Magneto Side KS	1	--	
	36 PF00 38	Kit Crankcase Magneto Side ES	--	1	
2	39 2562 20	Needle Roller Bearing	1	1	
3	59 2000 36	6203 Ball Bearing	1	1	
4	39 1715 19	Seal Oil	1	1	Output Shaft
5	31 2010 81	Switch Complete	1	1	Neutral Switch
6	DH 1017 84	Gasket Neutral Switch (T.I.S)	1	1	
7	39 2190 19	Oil Seal	1	1	Shifter Shaft
8	JA 5410 05	Bush Bendix	--	1	
9	39 0747 01	Screw Pan Cross M6	--	2	
10	JA 5410 34	Stopper Gear Starter Aluminium	--	1	
11	39 1000 06	Pin Dowel	4	4	
12	39 0999 06	Hollow Dowel Pin	4	4	
13	JG 5710 24	Mesh Oil Filter	1	1	
14	LJ A000 04	'O' Ring Strainer	1	1	
15	JV 5410 06	Cap Strainer	1	1	
16	JV 5410 07	Flange - Bolt	6	6	Crankcase Mounting
17	39 1759 04	Bolt (M6 X 1 X 55L)	1	1	Crankcase Mounting

Clutch Cover

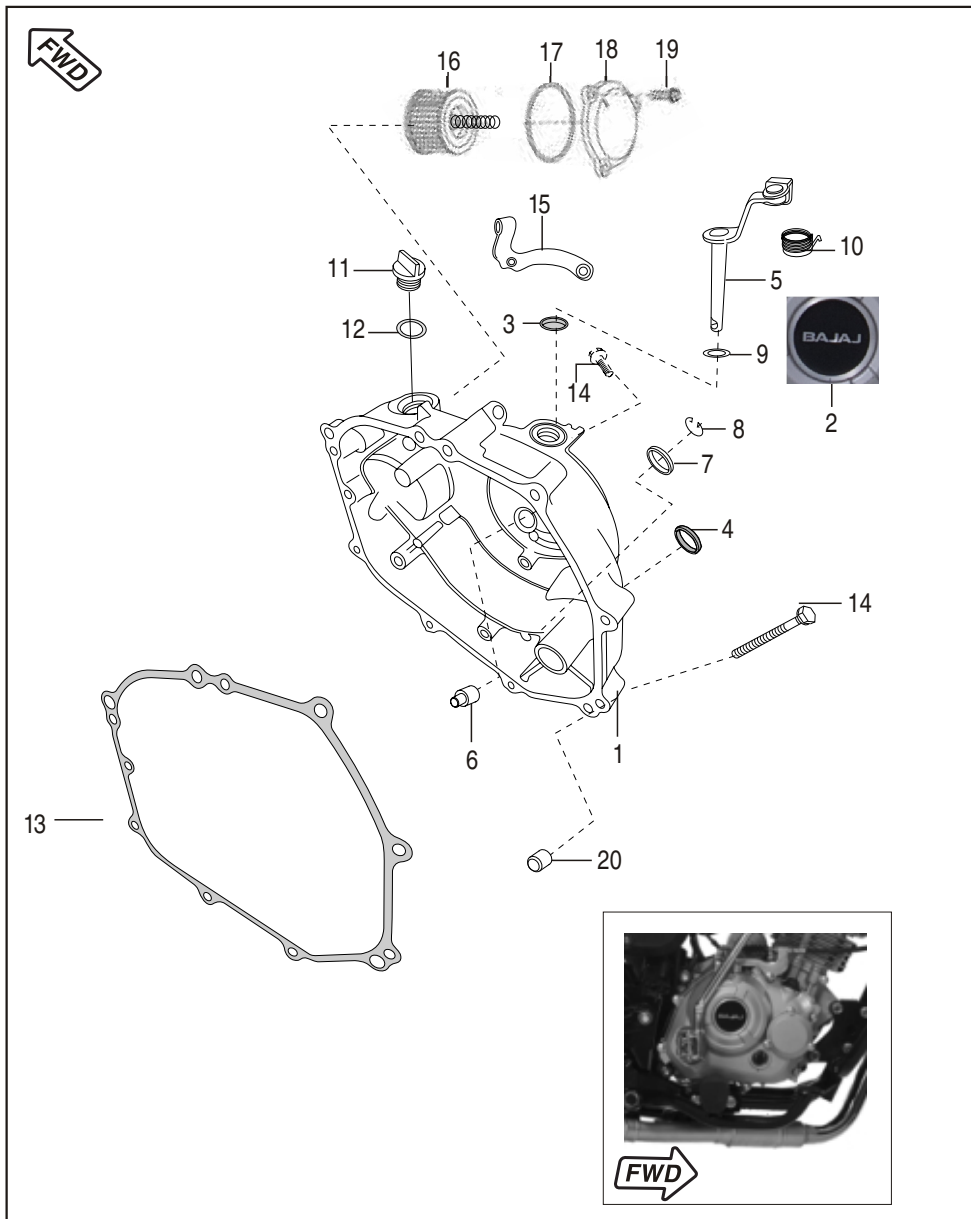

No.	Part No.	Description	Qty		Remarks
			KS	ES	
1	36 PF00 08	Kit Cover Clutch Assly. Complete	1	1	
2	JK 5412 14	Decal	1	1	
3	39 1041 19	Oil Seal Clutch Lever	1	1	
4	30 1011 42	Oil Seal (Kick Shaft)	1	1	
5	JV 5412 08	Shaft Clutch Release Assly	1	1	
6	DP 1012 69	Rod Push	1	1	
7	DG 1014 18	Gauge	1	1	Oil Level Check
8	DS 1012 15	Wire Circilp	1	1	
9	JA 5412 36	Plain Washer	1	1	
10	JA 5412 37	Spring Torsion Clutch Lever	1	1	
11	JA 5412 11	Cap Oil Filler	1	1	
12	JA 5412 25	'O' Ring Cap Oil Filler	1	1	
13	JA 5412 12	Gasket Clutch Cover	1	1	
14	JV 5412 15	BOLT M6X40 Silver Color	8	8	
15	JV 5412 09	Bracket Clutch Cable	1	1	
16	DD 1211 81	Oil Filter Element	1	1	
17	39 1671 21	'O' Ring	1	1	
18	JV 5412 05	Cap Filter	1	1	
19	JA 5210 19	Bolt Flange	3	3	
20	39 0999 06	Pin Hollow Dowel	2	2	

Cover Magneto

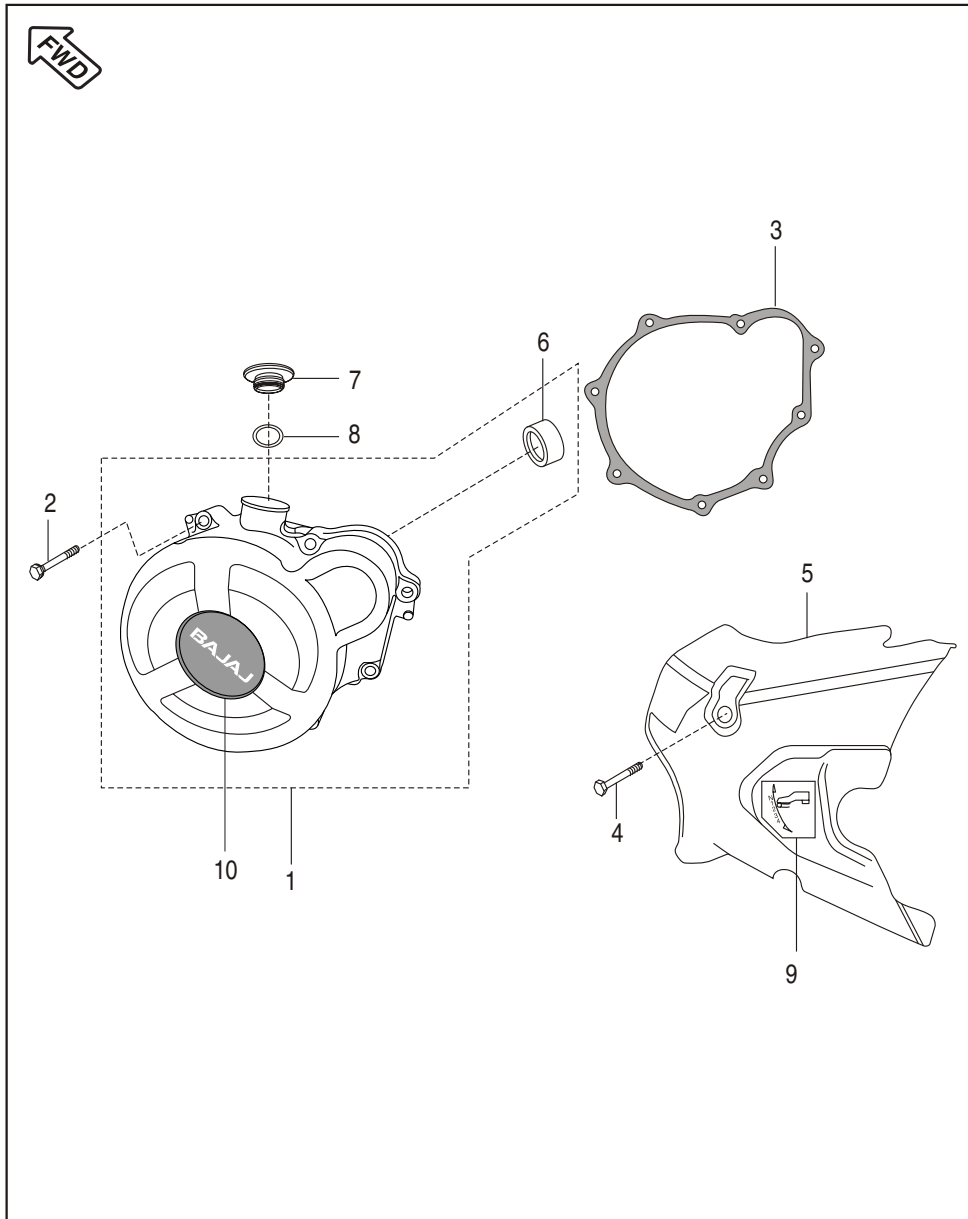

No.	Part No.	Description	Qty		Remarks
			KS	ES	
1	PF 5412 11	Cover Magneto KS	1	--	
	36 PF00 07	Kit Cover Magneto Assly ES	--	1	
2	JV 5412 15	Bolt M8 Silver colour	8	8	
3	JP 5412 08	Gasket Magneto Cover KS	1	--	
	JA 5412 05	Gasket Magneto Cover ES	--	1	
4	JV 5410 07	Bolt	2	2	
5	JV 5412 06	Cover LH Rear Complete	1	--	
	JV 5412 12	Cover LH Rear Complete	--	1	
6	JA 5410 05	Bush	--	1	For Drive Gear Assly
7	JA 5412 33	Cap TDC Finder	1	1	
8	30 1011 95	'O' Ring	1	1	
9	DS 1611 50	Sticker Gear Shifting	1	1	
10	JK 5412 14	Decal Magneto Cover	1	1	

Clutch Assembly

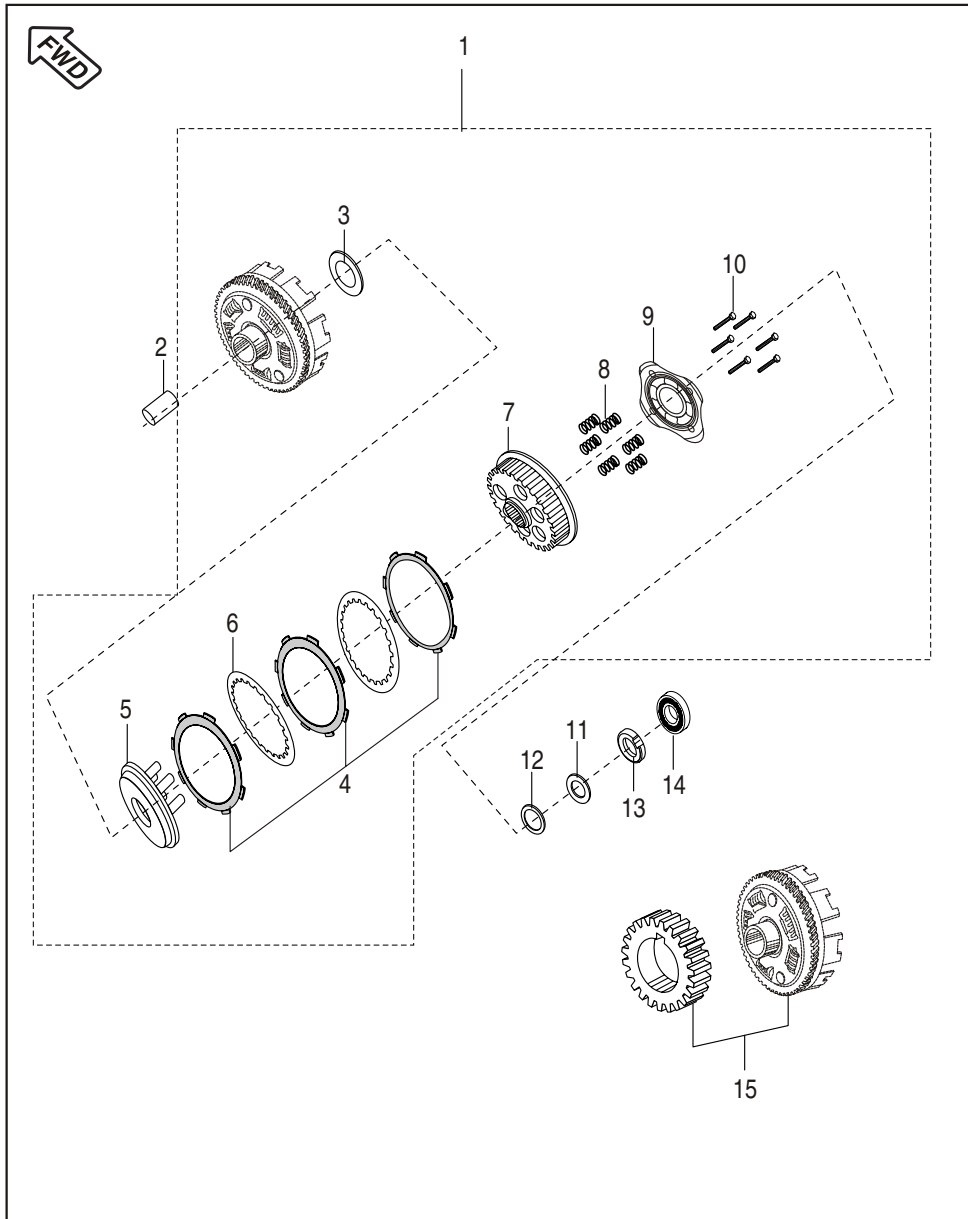

No.	Part No.	Description	Qty		Remarks
			KS	ES	
1	JZ 5514 13	Clutch Assembly Complete	1	1	
2	JA 5514 06	Collar Clutch	1	1	
3	39 2600 11	Washer	1	1	
4	36 JZ00 37	Kit Plate Friction	1	1	Refer Page No. 91
5	JB 5514 08	Wheel Clutch	1	1	
6	30 1010 96	Plate Clutch (Steel Plate)	4	4	
7	JB 5514 11	Hub Clutch (Modified)	1	1	
8	JZ 5514 15	Spring Clutch	6	6	
9	JB 5514 06	Holder Clutch (Modified)	1	1	
10	39 0980 04	Bolt Hexagon Head	6	6	
11	39 1057 11	Belleville Washer	1	1	
12	JA 5514 20	Plain Washer	1	1	
13	52 JA00 28	Nut Special M14	1	1	
14	39 1001 20	Bearing Ball	1	1	
15	36 JZ00 23	Set Primary Drive & Driven	1	1	Refer Page No. 91

Kick Starter Mechanism

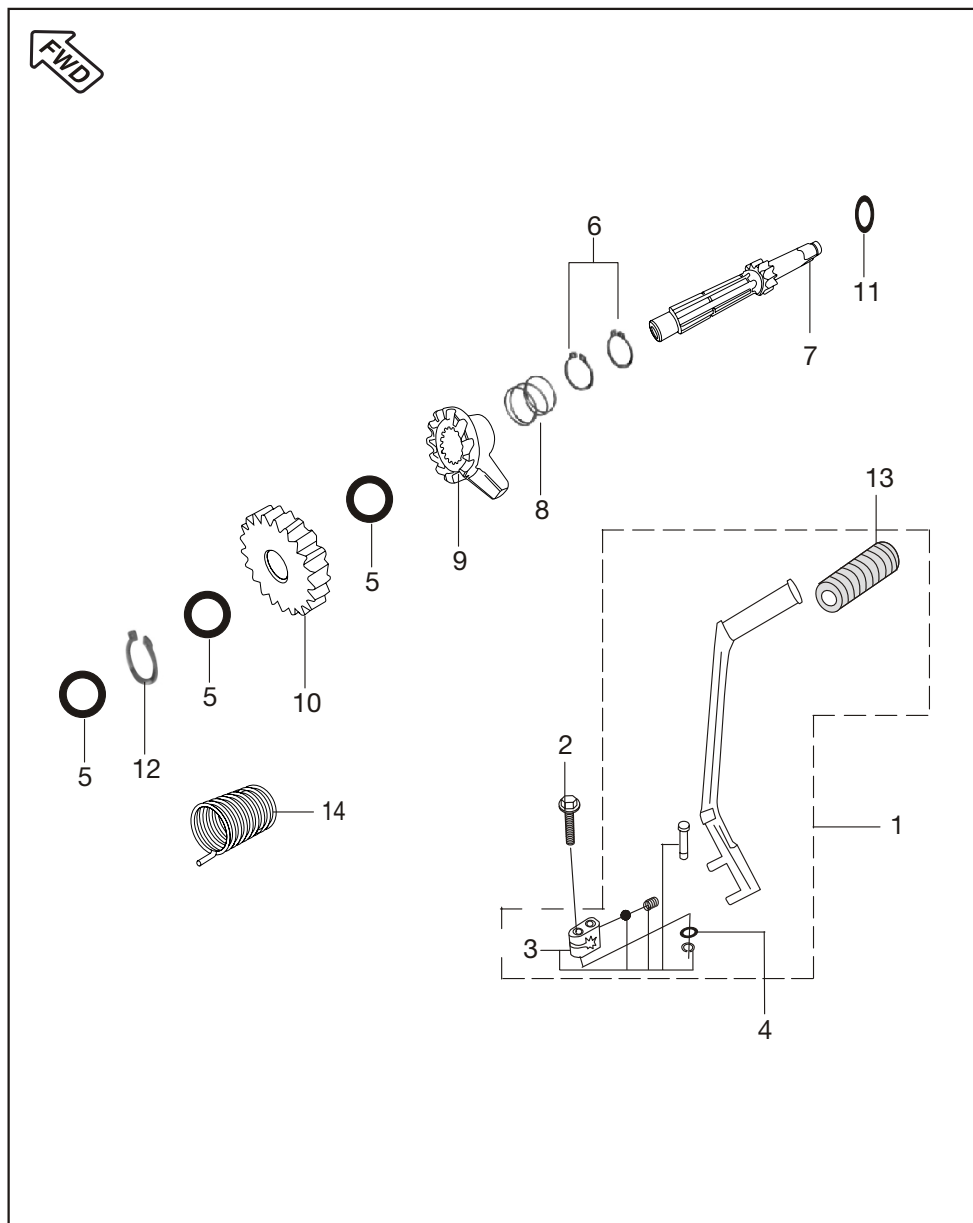

No.	Part No.	Description	Qty		Remarks
			KS	ES	
1	JA 6212 01	Lever Assly Kick	1	1	Refer Page No. 91
2	JA 6212 06	Bolt Flange	1	1	
3	36 DU10 07	Boss	1	1	
4	22 1502 41	Plain Washer	1	1	
5	39 0993 11	Plain Washer Small	3	3	
6	39 0738 17	Circlip Shaft	2	2	
7	JA 6210 01	Shaft Kick	1	1	
8	DS 1011 17	Spring Kick Starter Ratchet	1	1	
9	JA 6210 02	Ratchet	1	1	
10	JZ 6210 00	Gear Kick Pinion	1	1	
11	JA 6210 06	Washer Thrust (16.2 X 25 X 0.5)	1	1	
12	39 2408 17	Circlip	1	1	
13	DD 1010 97	Kick Rubber	1	1	
14	JE 5410 08	Spring Kick Starter Return	1	1	

Carburettor

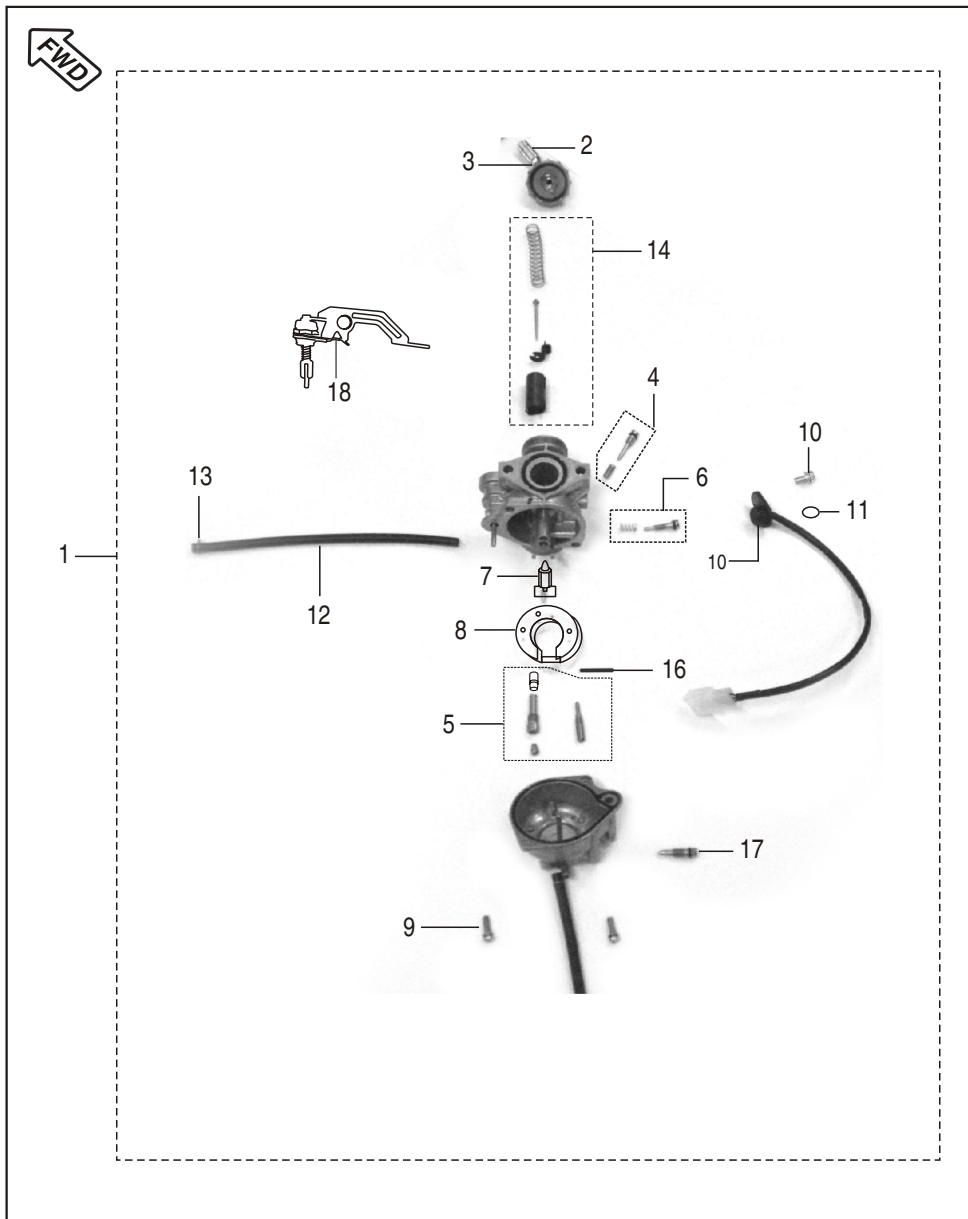

No.	Part No.	Description	Qty		Remarks
			KS	ES	
1	PF 5813 00	Carburettor assly.	1	1	
2	JB 5812 37	Adjuster throttle cable	1	1	
3	JB 5812 38	Nut adjuster	1	1	
4	36 PF00 33	Air screw Kit	1	1	Refer Page No. 93
5	36 PF00 32	Kit Jet Needle	1	1	Refer Page No. 93
6	36 PA00 13	Idling screw kit	1	1	Refer Page No. 92
7	JB 5812 29	Valve complete float (Float pin)	1	1	
8	JB 5812 30	Float complete	1	1	
9	JB 5812 32	Screw washers M4x14	1	1	
10	JB 5812 02	Throttle position sensor	1	1	
11	JB 5812 04	"O" Ring (TPS)	1	1	
12	PF 5813 08	Tube	1	1	
13	JB 5812 59	Clip	1	1	
14	36 PF00 34	Throttle Value Kit	1	1	Refer Page No. 93
15	36 PA00 15	Carb. Gasket 'O' ring	1	1	N.I. Refer Page No. 92
16	JB 5812 56	Arm Pin Float	1	1	
17	JB 5812 60	Drain Screw	1	1	
18	PF 5813 09	Lever Complete Starter	1	1	

Air Cleaner Complete

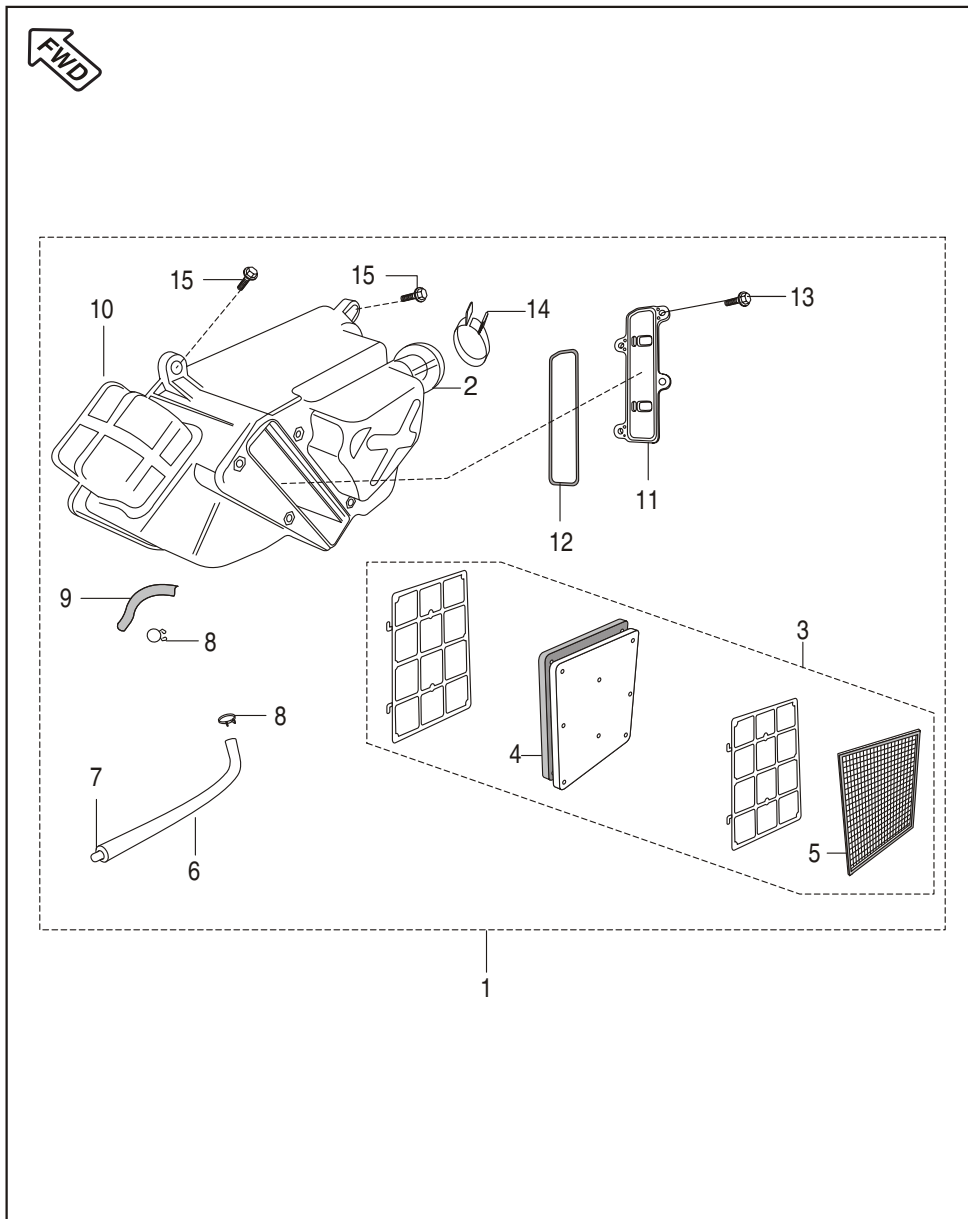

No.	Part No.	Description	Qty		Remarks
			KS	ES	
1	PF 5810 00	Assembly Air Filter	1	1	
2	JB 5810 01	Duct Air Intake	1	1	
3	JA 5810 05	Assly Catridge Air filter	1	1	
4	JA 5810 06	Element Air Filter	1	1	
5	JA 5810 09	Flame Arrester	1	1	
6	JA 5810 12	Tube Drain	1	1	
7	DS 1211 26	Plug	1	1	
8	DP 1210 25	Clamp	1	1	
9	JA 5110 11	Hose Breather	1	1	
10	JB 5810 01	Air Intake Duct	1	1	
11	JA 5810 13	Cartridge Cover Assly	1	1	
12	JA 5810 11	'O' Ring Cartridge Cover	1	1	
13	39 1773 04	Flange Bolt	4	4	
14	DH 1210 38	Clamp	1	1	
15	DF 1614 26	Bolt - Stepped with Flange	2	2	

Silencer Assembly

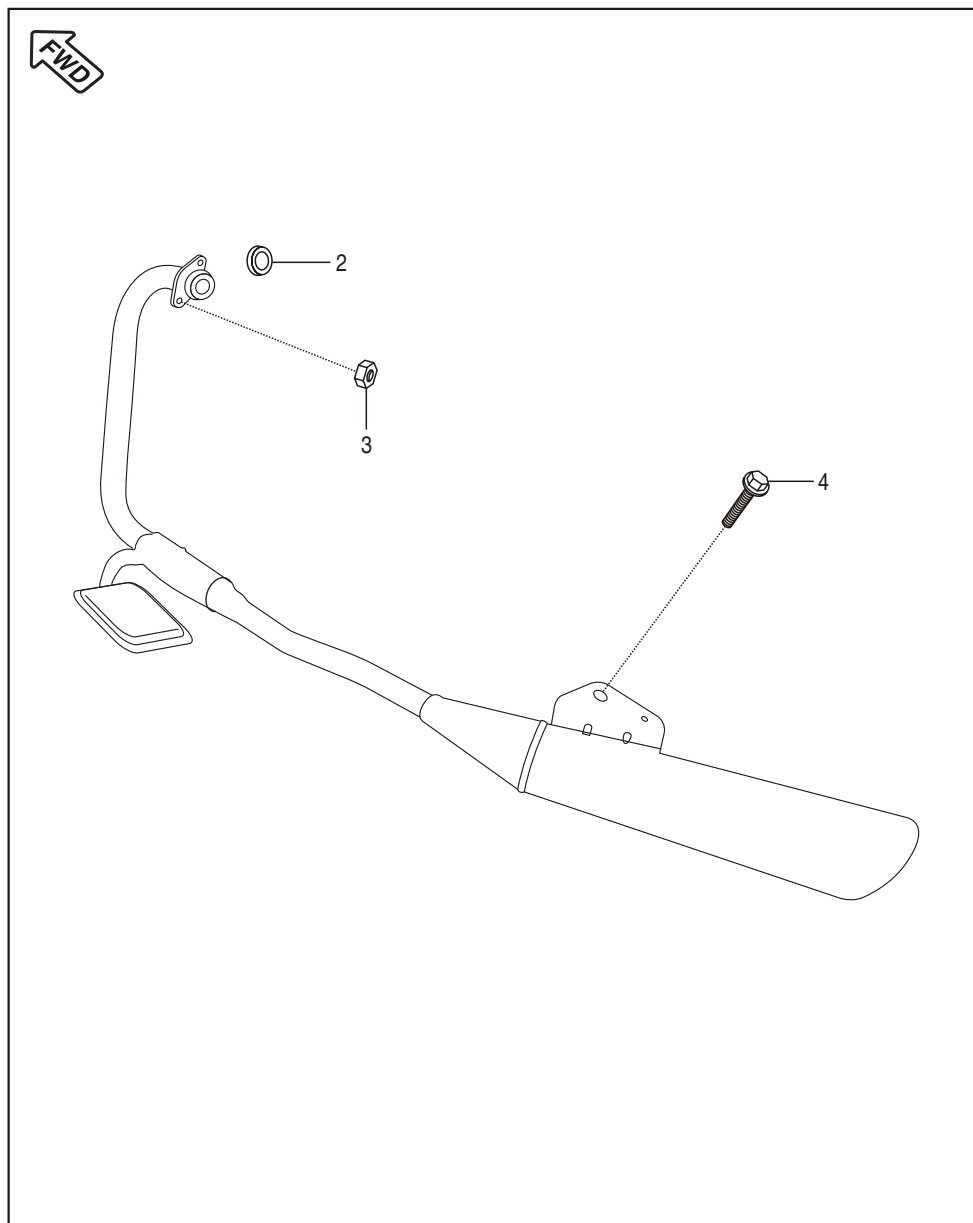

No.	Part No.	Description	Qty		Remarks
			KS	ES	
1	PF 5910 00	Assembly Silencer	1	1	
2	CB 1011 14	Gasket Exhaust Mounting	1	1	
3	39 2295 15	Flange Nut	2	2	
4	JB 2312 06	Bolt Hex. Socket Head	1	1	

Oil Pump

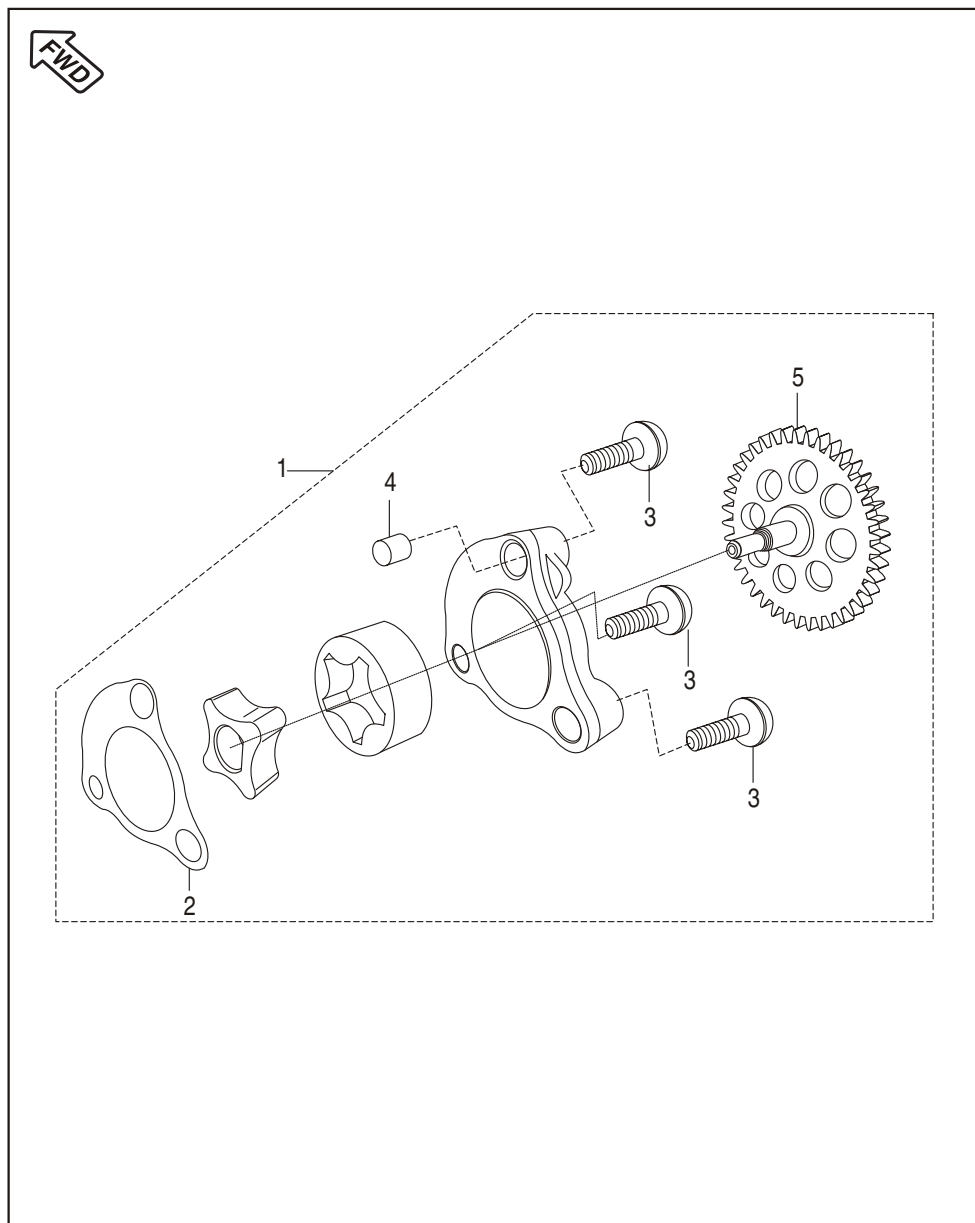

No.	Part No.	Description	Qty		Remarks
			KS	ES	
1	PF 5710 00	Oil Pump Assly	1	1	
2	JA 5410 16	Gasket Case Oil Pump	1	1	
3	FD 1010 78	Pan Head Screw M6 X 1 X 3DL	3	3	
4	39 0999 06	Dowel	2	2	
5	PF 5710 01	Gear Oil Pump	1	1	

Starter Assembly

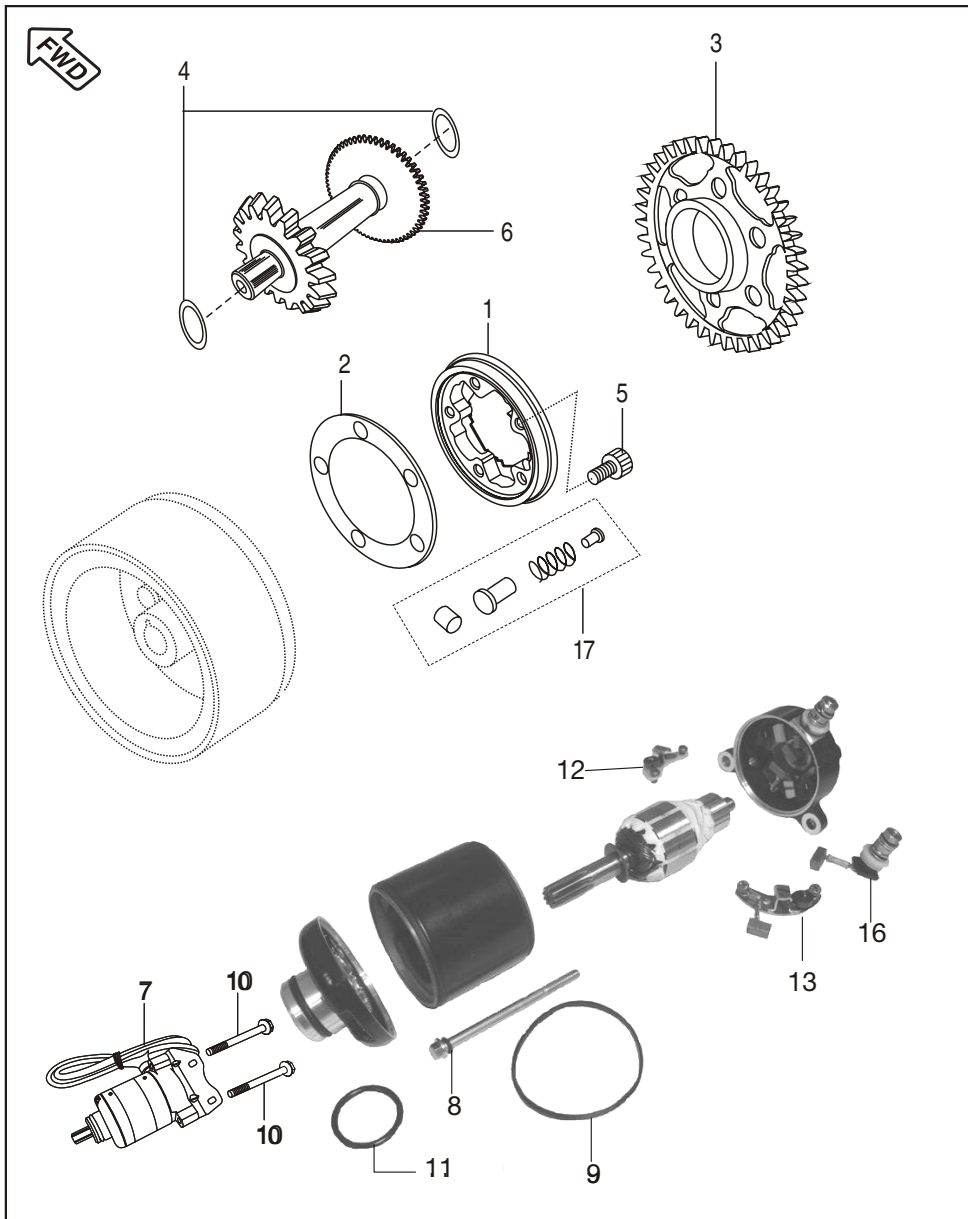

No.	Part No.	Description	Qty		Remarks
			KS	ES	
1	JA 6214 14	Body comp. starter clutch	--	1	
2	DH 1017 81	Plate roller clutch	--	1	
3	JA 6214 10	Gear starter clutch	--	1	
4	JA 6214 02	Washer	--	2	
5	39 2437 04	Bolt socket	--	3	
6	JA 6214 06	Starter drive assly.	--	1	
7	JV 3516 00	Motor Assly	--	1	
8	JA 3516 04	'O' Ring For Tie Bolt (Flash)	-	1	
9	JA 3516 06	Sealing Ring (Flash)	--	1	
	JA 3516 26	Sealing Ring (Lucas-TVS)	--	1	
10	DH 1011 63	Flange Bolt (Flash)	--	2	
11	JA 3516 02	'O' Ring For Spigot (Flash)	--	1	
	JA 3516 27	'O' Ring For Spigot (Lucas-TVS)	--	1	
12	JA 3516 08	+ve Brush Holder Assly (Flash)	--	1	
13	JA 3516 09	-ve Brush Holder Assly (Flash)	--	1	
14	JA 3516 18	Brush & Earth Plate Assly	--	1	N.I. (Lucas-TVS)
15	JA 3516 24	Brush Spring (Lucas-TVS)	--	1	N.I.
16	JA 3516 19	Terminal Assly (Lucas-TVS)	-	1	
17	36 JW0014	Starter Clutch Repair Kit	-	1	Ref. Page No. 91

Magneto, CDI & H.T. Coil

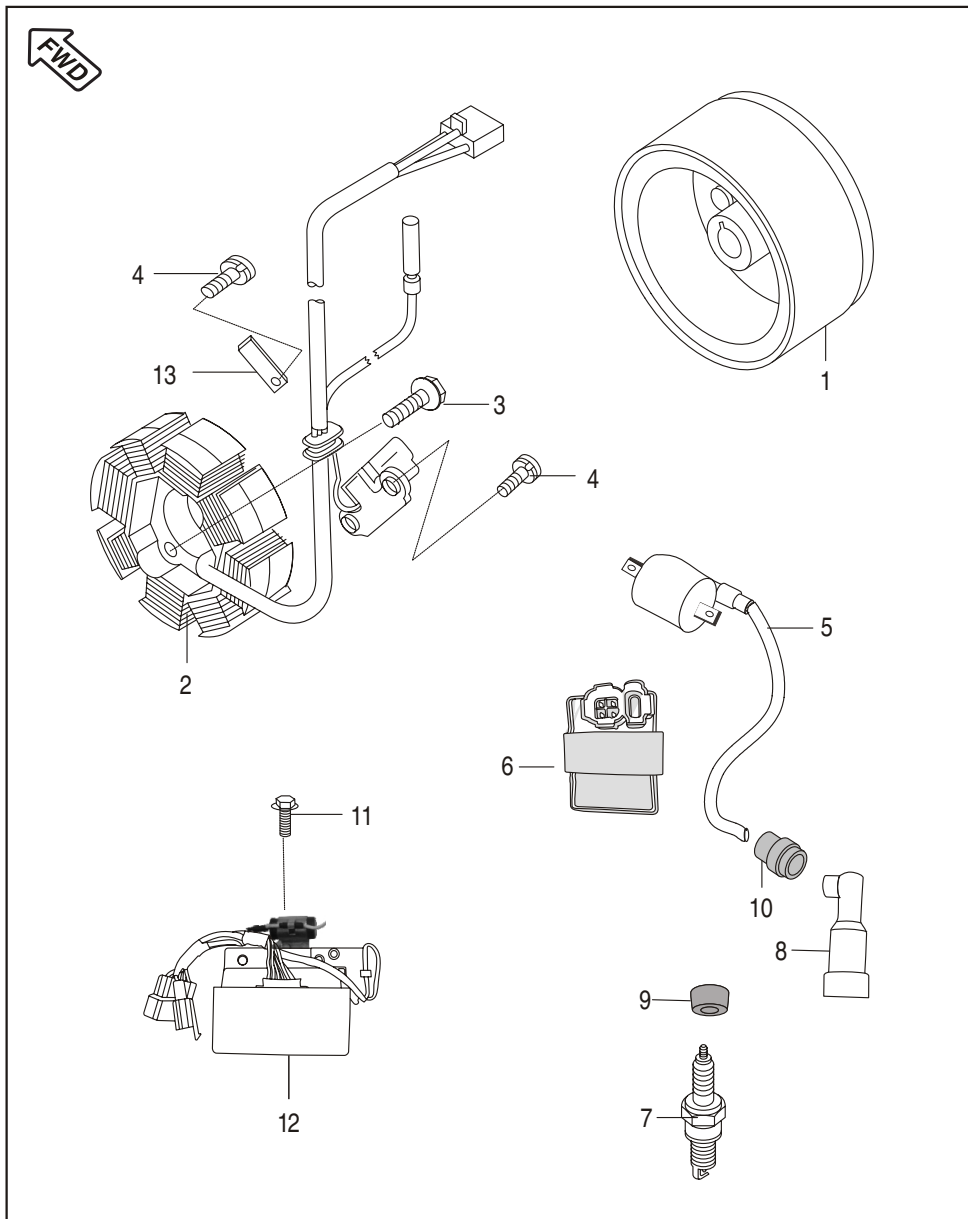

No.	Part No.	Description	Qty		Remarks
			KS	ES	
1	PF 3510 07	Rotor Assly	1	--	For Lock Plate & Pick Up Coil Mounting
	PF 3510 05	Rotor Assly	--	1	
2	PF 3510 04	Stater Assly Complete1	1	--	
	PF 3510 06	Stater Assly Complete	--	1	
3	39 1674 04	Bolt Flange M6 X 28	2	2	
4	DH 1013 80	Pan Head Screw M6 X 12	2	3	
5	JV 3512 04	H. T. Coil With Cable	1	1	
6	PF 3512 00	CDI AC STEP UP	1	1	
7	DD 1110 18	Spark Plug PRZ9 HC / UR4AC	1	1	
8	DD 1110 48	Spark Plug Cap LH	1	1	
9	DD 1110 11	Grommet Spark Plug Cap LH	1	1	
10	DD 1110 12	Grommet for HT Cable	1	1	
11	39 1943 04	Bolt Flange M6	2	2	
12	JN 4020 00	Regulator With Capacitor	1	1	
13	JA 5410 28	Lock Plate	--	1	

FRAME & FRAME FITTING

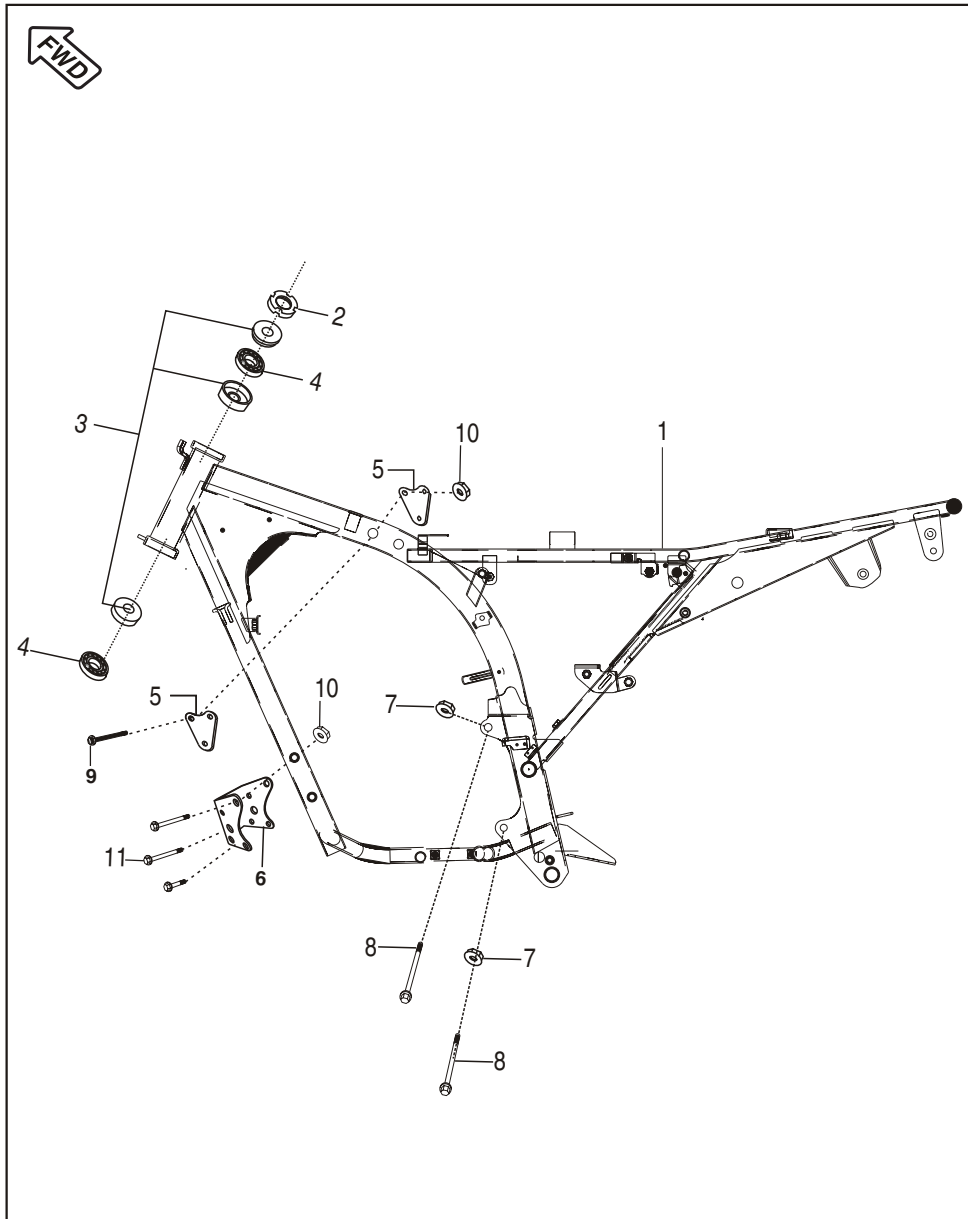

No.	Part No.	Description	Qty		Remarks
			KS	ES	
1	PF 1110 00	Frame Assly.	1	1	
2	DF 1810 90	Nut Steering Bearing	1	1	
3	36 3140 01	Bearing cone Kit	1	1	Ref. Page No. 91
4	DJ 1811 15	Cage Bearing	2	2	
5	PF 1134 00	Bracket engine hanger LH	1	1	
	PF 1134 01	Bracket engine hanger RH	1	1	
6	JA 1134 02	Engine Mounting bracket front	1	1	
7	39 2723 15	Hex Nut Flanged	2	2	for engine mtg. Rear
8	JA 1134 03	Bolt Flanged	2	2	for engine mtg. Rear
9	39 2312 04	Bolt Flanged	3	3	for engine mtg. Top
10	39 1970 15	Nut Flanged	7	7	for engine mtg. Top & Front
11	59 0400 17	Hex Bolt Flanged	4	4	for engine mtg. Front

SWING ARM / REAR SHOCK ABSORBER

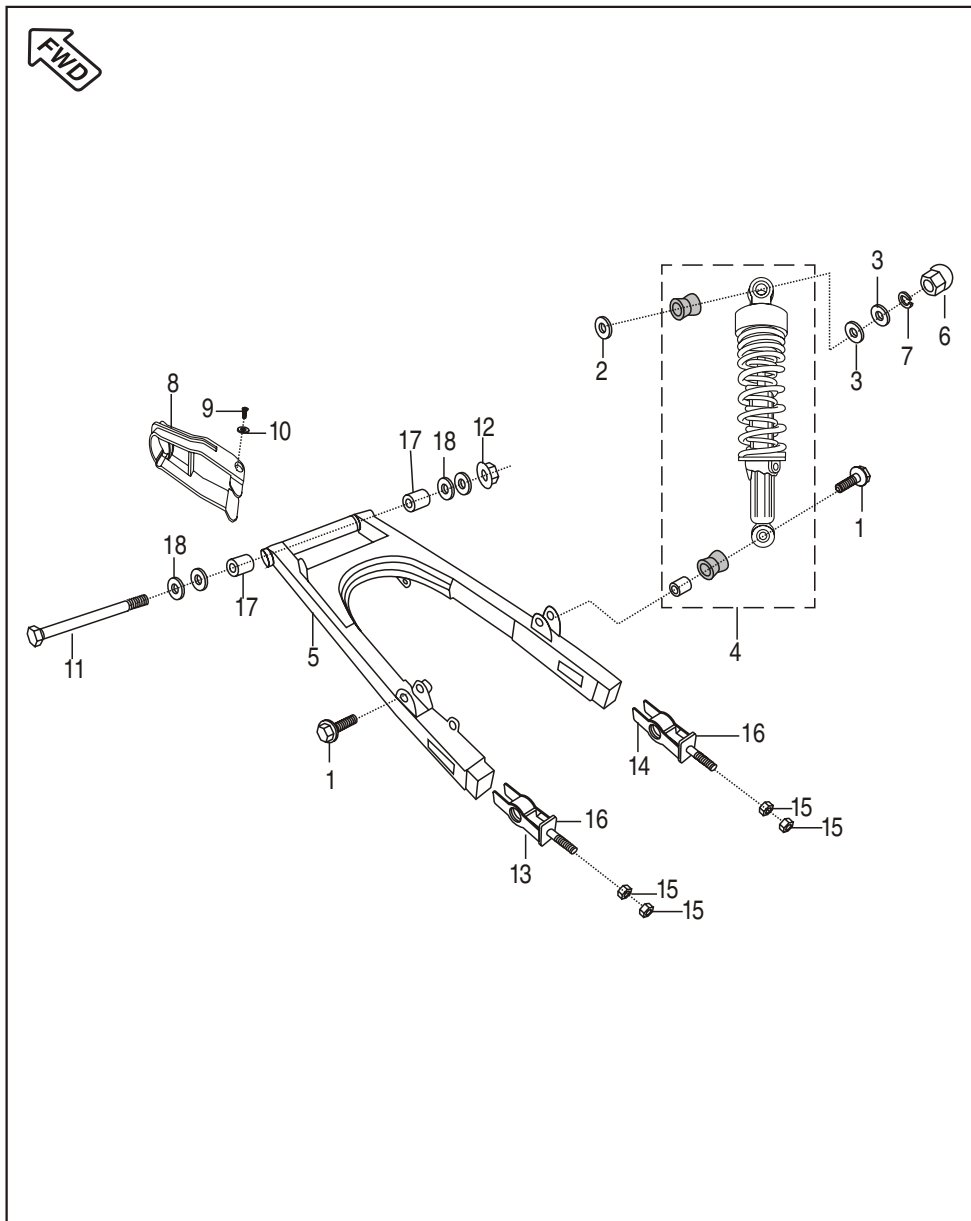

No.	Part No.	Description	Qty		Remarks
			KS	ES	
1	JB 1220 16	Hex. Bolt/ Flange	2	2	
2	39 0714 11	Plain washer	2	2	
3	39 2349 11	Plain washer	4	4	
4	PF 1220 04	Rear Shock Absorber (SNS)	2	2	
5	36 PF00 14	Assly. Swing Arm	1	1	
6	39 2366 15	Domed Cap Nut	2	2	
7	39 0789 12	Spring Washer	2	2	
8	JB 1220 03	Chain slider	1	1	
9	39 0553 02	Self Tapping Screw	2	2	
10	39 0454 11	Plain washer	2	2	
11	JA 1210 03	Shaft Swing Arm	1	1	
12	39 0939 15	Special Nylock Nut	1	1	
13	DJ 1510 36	Adjuster chain LH	1	1	
14	DJ 1510 37	Adjuster chain RH	1	1	
15	39 0292 15	Hexagon nut	4	4	
16	DJ 1510 47	Plate Chain Adjuster	2	2	
17	DP 1710 06	Silent bush	2	2	
18	39 0781 11	Washer Plain	4	4	

Fender - Front & Rear

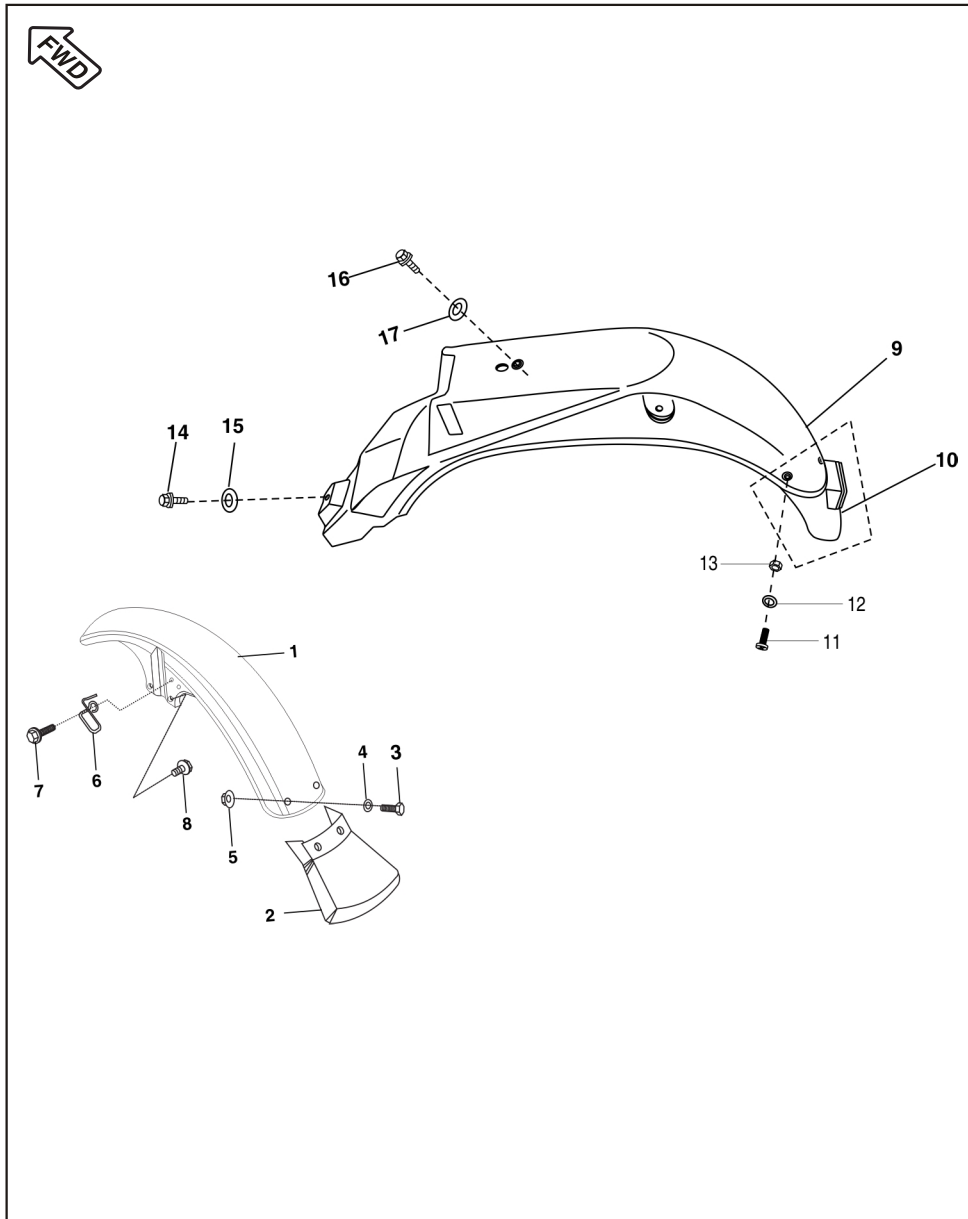

No.	Part No.	Description	Qty		Remarks
			KS	ES	
1	DF 1612 42	Fender Front	1	1	
2	DF 1612 45	Mud Flap Front	1	1	
3	22 1504 35	Bolt	2	2	
4	01 1106 09	Washer Plain	2	2	
5	39 2484 15	Nut Flange M5	2	2	
6	DF 1910 20	Clamp	1	1	
7	39 2473 04	Bolt Flange	1	1	
8	39 2222 04	Bolt Flange M8	4	4	
9	JV 1814 08	Fender Rear (Combined)	1	1	
10	JV 1814 10	Flap Fender Rear	1	1	
11	39 2420 01	Screw Pan Head	3	3	
12	39 1839 11	Washer Plain	6	6	
13	39 0326 15	Nut Nyloc M5 X 0.8	3	3	
14	39 1943 04	Bolt Flange	1	1	
15	39 0211 11	Washer Plain	1	1	
16	39 1556 04	Hex. Bolt Flange M8	1	1	
17	39 1507 11	Washer Plain	1	1	

Foot Rest / Holder / Stand

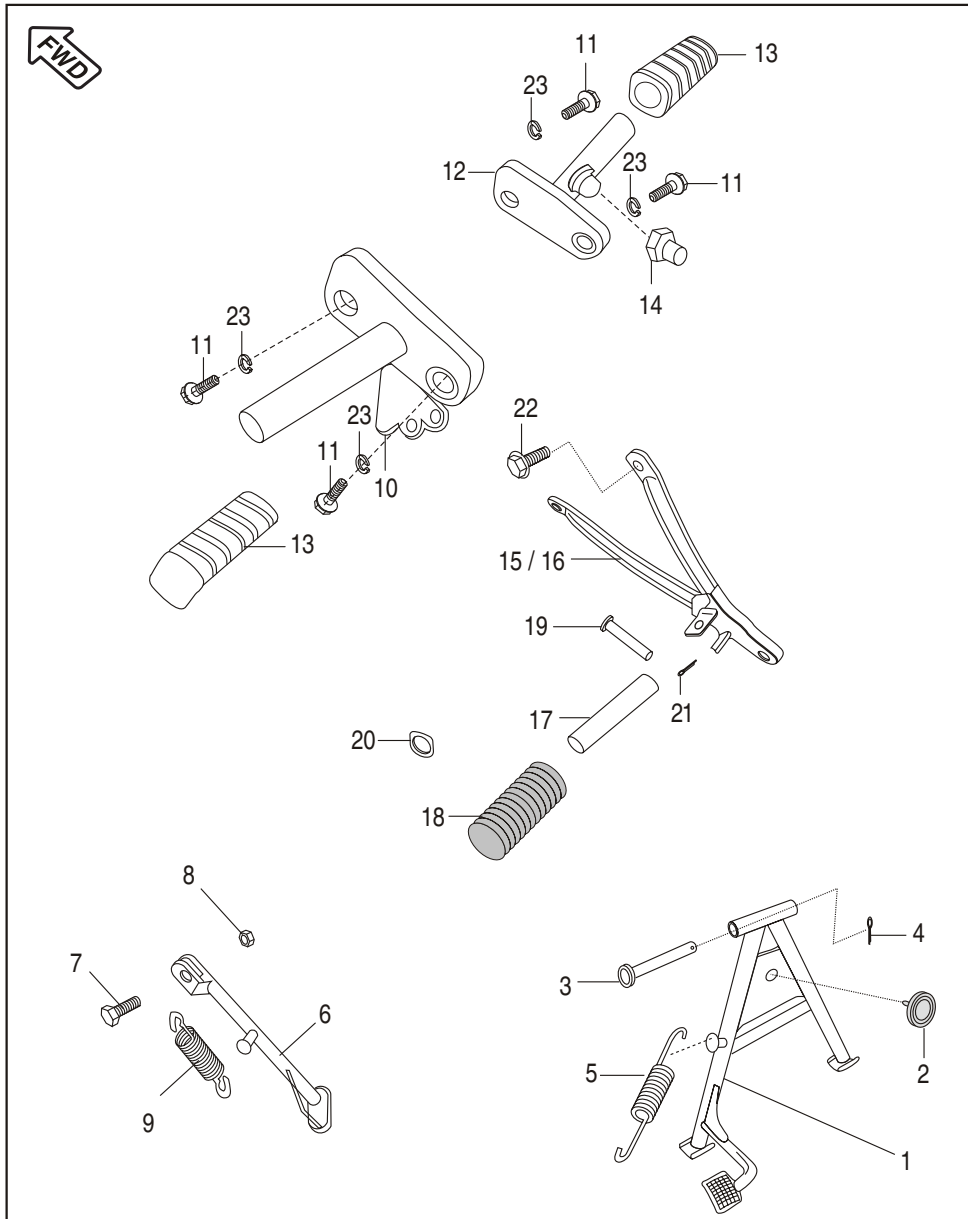

No.	Part No.	Description	Qty		Remarks
			KS	ES	
1	PF 1132 00	Center Stand	1	1	
2	DG 1611 24	Damper Stand	1	1	
3	JA 1132 01	Shaft Stand	1	1	
4	39 0797 08	Pin Cotter	1	1	
5	DH 1611 21	Spring Main Stand	1	1	
6	JA 1132 02	Side Stand	1	1	
7	DF 1611 02	Bolt for Side Stand Mtg.	1	1	
8	39 0422 15	Nut Nyloc M10	1	1	
9	DH 1610 66	Spring Side Stand	1	1	
10	PF 1130 00	Main Step LH	1	1	
11	KA DF08 22	Bolt Flanged	4	4	
12	PF 1130 01	Main Step RH	1	1	
13	DF 1614 13	Rubber Main Step	2	2	
14	DH 1611 94	Kick Stopper	1	1	For Kick stopper
15	PF 1130 02	Stay LH	1	1	
16	PF 1130 03	Stay RH	1	1	
17	DP 1611 70	Step RH / LH	2	2	
18	JK 1130 08	Rubber Pillion Step	2	2	
19	30 1710 22	Pin Pillion Step	2	2	
20	DP 1611 63	Washer for foot step	2	2	For Rear Footrest
21	39 0784 08	Split Pin	2	2	
22	39 2481 04	Bolt Hex With Flange M8	4	4	
23	39 2659 12	Washer - Spring	4	4	

Wheel Rim / Spokes / Tyre / Tube

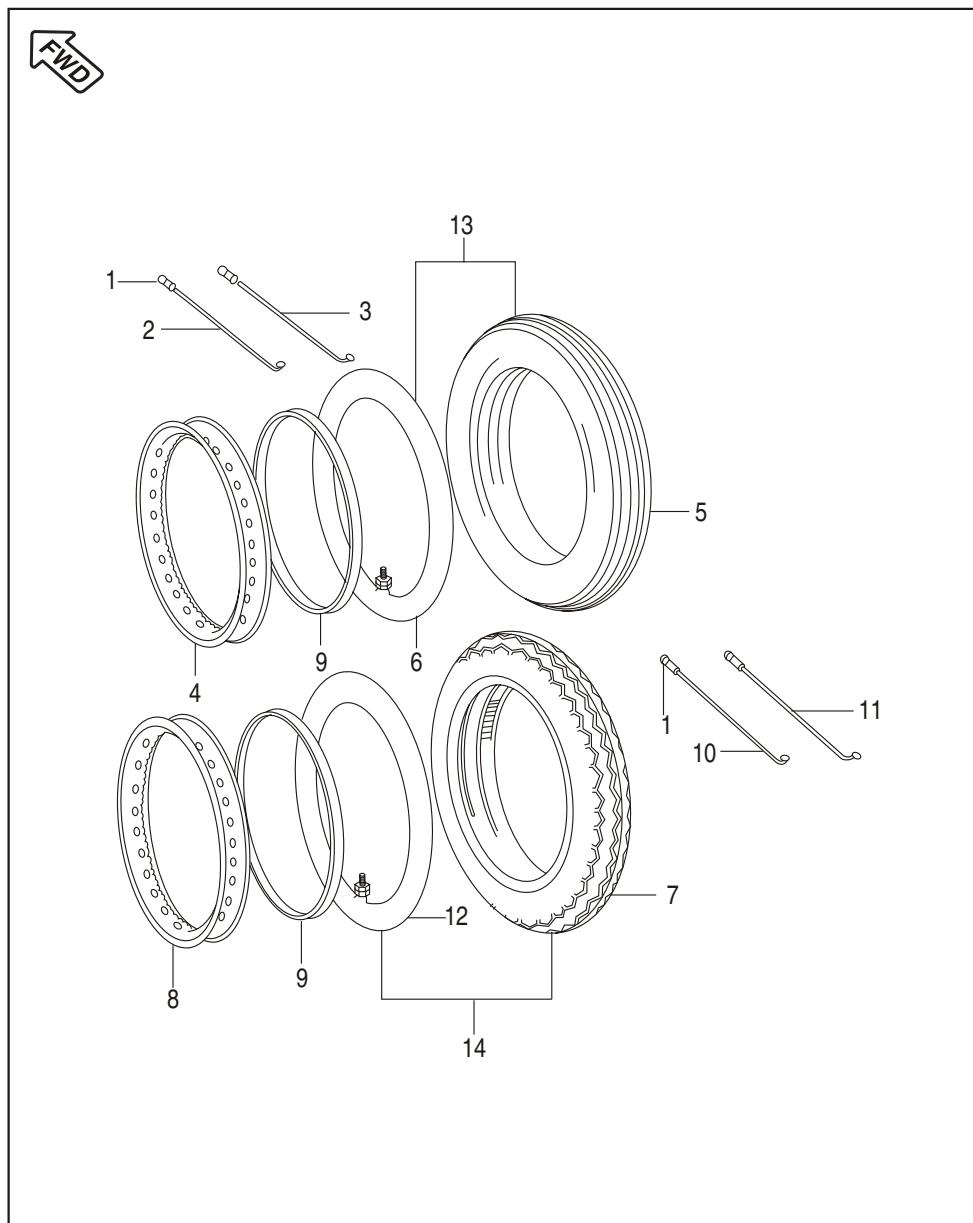

No.	Part No.	Description	Qty		Remarks
			KS	ES	
1	16 1510 66	Nipple Spoke	72	72	
2	DU 1510 25	Spoke Inner Front (Drum)	18	18	
3	DU 1510 26	Spoke Outer Front	18	18	
4	DM 1510 29	Rim - 1.60 X 17 Drum bake -Dia. 110	1	1	
5	DM 1510 25	Tyre :- 2.75-17, 4 PR, RIB Pattern	1	1	
6	DS 1510 49	Tube - 2.75 X 17	1	1	
7	DM 1510 28	Tyre :- 3.00-17, 6PR, Stud Paterne	1	1	
8	DS 1510 46	Rim 1.85 X 17 Rear	1	1	
9	DG 1510 22	Band Rim	2	2	
10	DS 1510 09	Spoke Inner Rear	18	18	
11	DS 1510 10	Spoke Outer Rear	18	18	
12	DS 1510 53	TUBE - 3 X 17	1	1	
13	DS 1510 47	Tyre and Tube Front	1	1	
14	DM 1510 27	Tyre and Tube Rear	1	1	

Front Hub

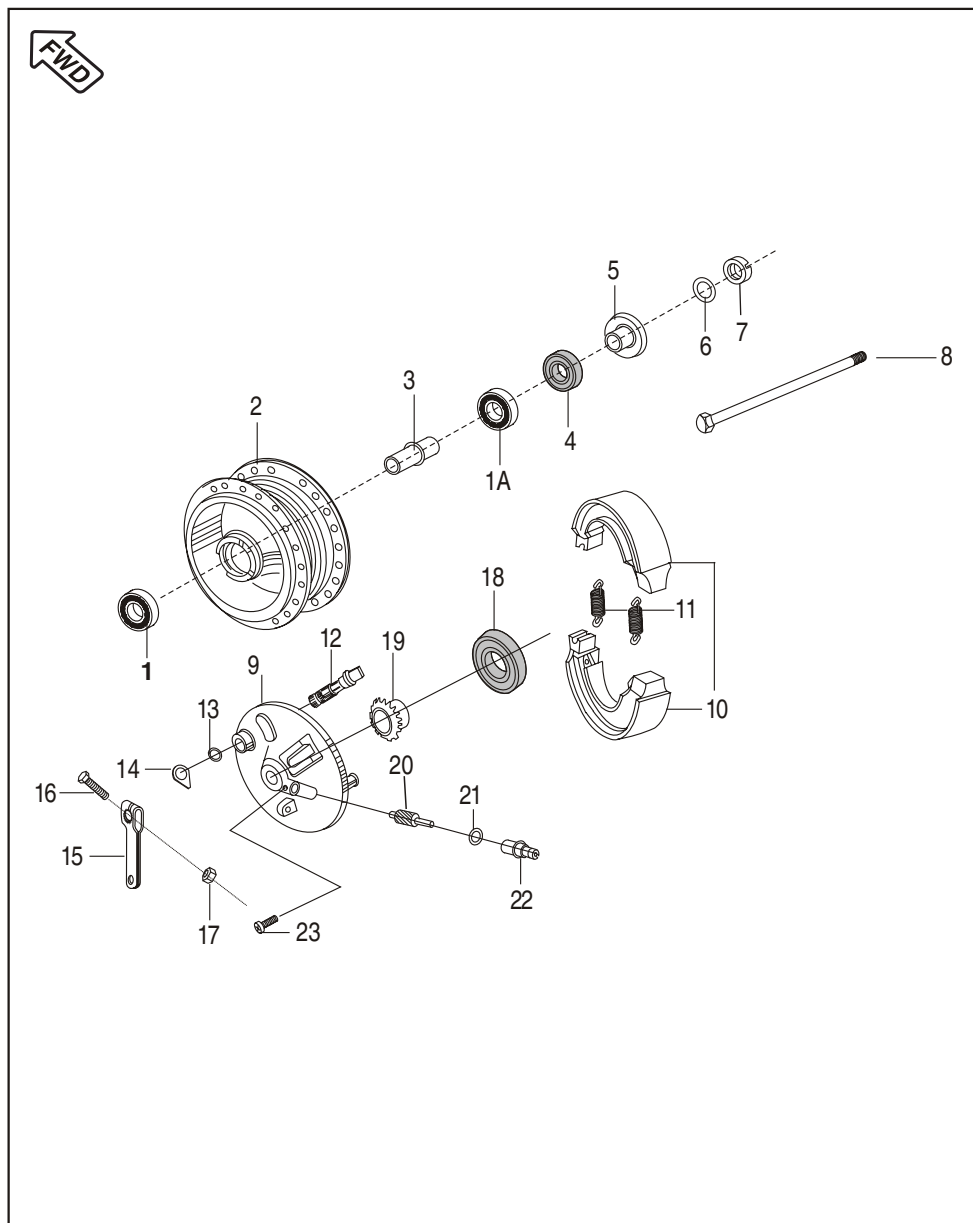

No.	Part No.	Description	Qty		Remarks
			KS	ES	
1	39 2680 20	Ball Bearing 10X35X11 -	1	1	6300 1RS/C3
1A	39 2681 20	Ball Bearing 10X30X9 -	1	1	6200 1RS/C3
2	DF 1510 03	Drum Front	1	1	
3	31 1510 04	Spacer	1	1	
4	14 1510 21	Oil Seal 30 X 17 X 6	1	1	
5	DU 1510 05	Collar Assly Axle	1	1	
6	39 0248 11	Plain washer	1	1	
7	DU 1510 31	NUT - U :- M10 X 1.25	1	1	
8	DZ 1510 12	Axle Front	1	1	
9	DZ 1510 27	Panel Front Brake	1	1	
10	31 1510 60	Shoe Brake	1	1	
	JB 1318 04	Shoe Brake (Non Asbestos)	1	1	
11	30 1510 69	Spring	2	2	
12	31 1510 11	Cam Brake	1	1	
13	30 1510 38	'O' Ring	1	1	
14	DD 1510 09	Indicator Front	1	1	
15	DD 1510 08	Lever Brake Cam	1	1	
16	39 0775 04	Bolt M6 X 30	1	1	
17	39 0798 15	Nut Hex. Flange M6	1	1	
18	31 1510 14	Seal Oil	1	1	
19	31 1510 64	Gear Speedometer	1	1	
20	30 1510 41	Gear Meter Screw	1	1	
21	30 1510 42	Washer for Speedo Gear	1	1	
22	JA 1316 06	Bush for Speedo Gear	1	1	
23	39 0840 01	Screw Pan Cross M4 for Speedo Cable	1	1	

Rear Hub

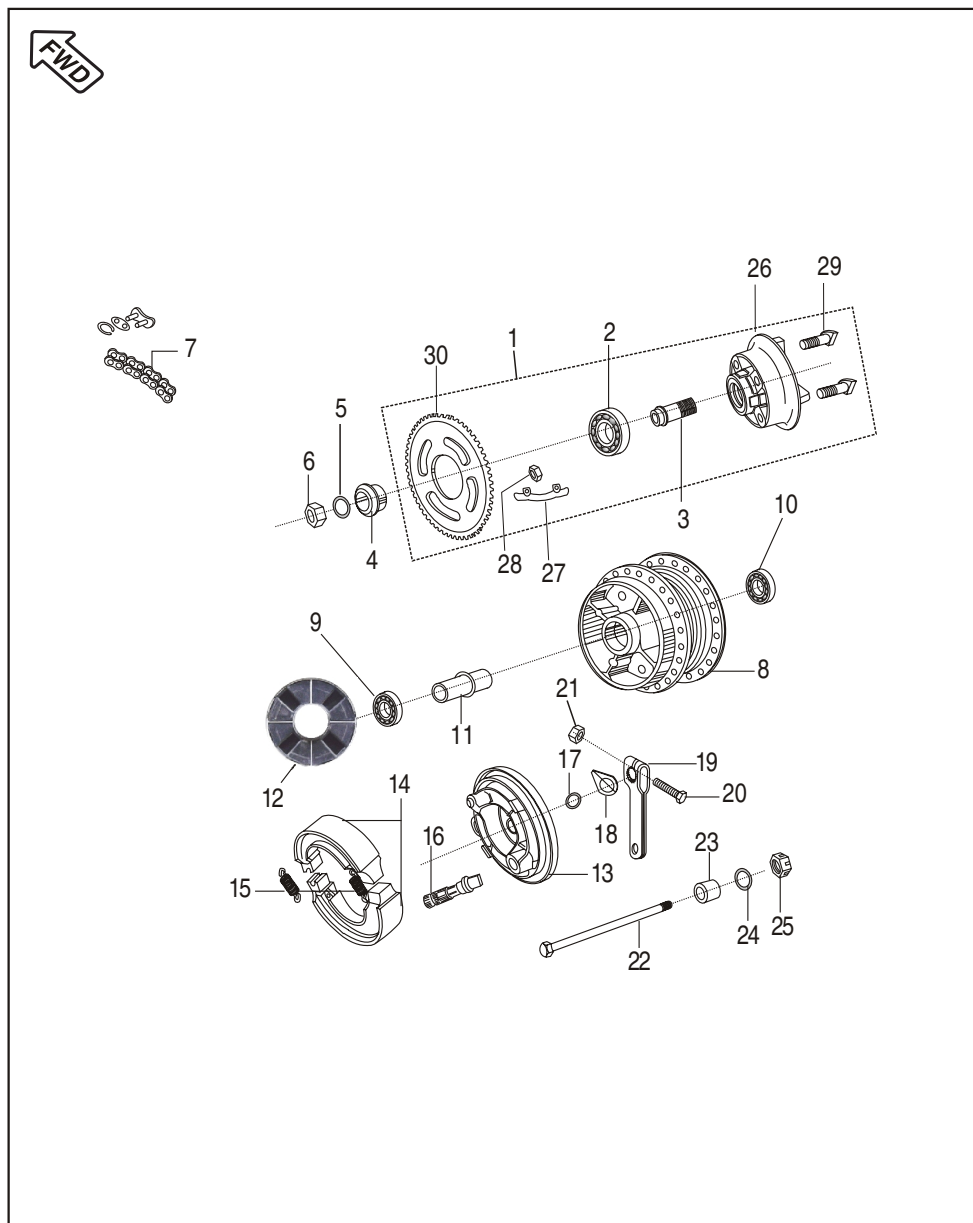

No.	Part No.	Description	Qty		Remarks
			KS	ES	
1	PF 1312 13	Coupling Assly.	1	1	
2	39 2240 20	Ball Bearing	1	1	
3	DJ 1510 33	Sleeve Rear Axle	1	1	
4	DJ 1510 35	Collar Coupling Side	1	1	
5	39 2567 11	Washer Plain	1	1	
6	39 0801 15	Nut Hex. M20 X 1	1	1	
7	PF 1410 02	Chain 124 Links (Cross Slit)	1	1	
8	DS 1510 67	Drum Rear (4 Rubber)	1	1	
9	39 2686 20	Bearing Sprocket Side	1	1	
10	39 2687 20	Bearing Brake Side	1	1	
11	30 1510 75	Collar Bearing	1	1	
12	DK 1510 94	Damper Shock	1	1	
13	DS 1510 76	Panel Rear Brake	1	1	
14	30 1511 05	Shoe Brake	1	1	
	JN 1318 12	Shoe Brake (Non Asbestos)	1	1	
15	30 1510 69	Spring	2	2	
16	30 1510 11	Cam Brake Assly. Rear	1	1	
17	30 1510 38	Ring 'O'	1	1	
18	DD 1510 09	Indicator Wear	1	1	
19	JW 1316 01	Lever Brake Rear	1	1	
20	39 0775 04	Hex. Head Bolt M6	1	1	
21	39 0798 15	Nut M6	1	1	
22	PF 1312 08	Axle Rear Wheel (Dia.15)	1	1	
23	PF 1312 04	Spacer Panel Side	1	1	
24	39 2566 11	Washer Plain	1	1	
25	DH 1710 19	Nut 'U' M14 Swing Arm	1	1	
26	DS 1510 68	Coupling	1	1	
27	DS 1510 74	Washer 4 Rubber	2	2	
28	39 0794 15	Nut Hex Fine M10 x 1.25	4	4	
29	DS 1510 73	Stud 4 Rubber	4	4	
30	DX 1510 21	Sprocket 46 T - 4 Rubber	1	1	

BRAKE PEDAL

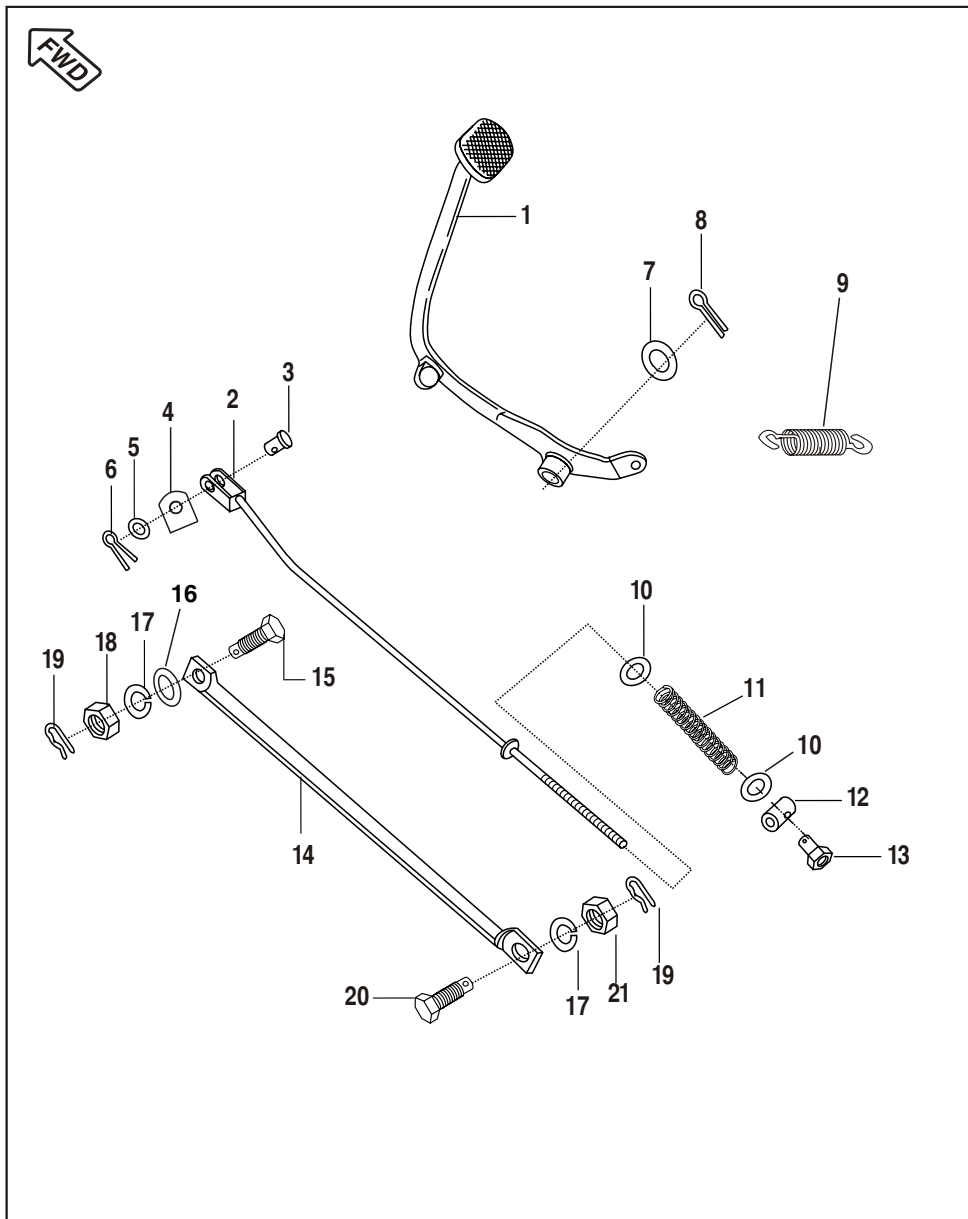

No.	Part No.	Description	Qty		Remarks
			KS	ES	
1	PF 1610 02	Brake Pedal	1	1	
2	PF 1610 01	Rod brake	1	1	
3	30 1910 38	Pin	1	1	
4	DS 1910 35	Packing Brake rod	1	1	
5	39 0198 11	Plain washer	2	2	
6	39 0808 08	Split pin	1	1	
7	39 0805 11	Plain Washer	1	1	
8	39 0797 08	Pin Cotter	1	1	
9	JV 1610 14	Brake Pedal Return Spring	1	1	
10	39 0198 11	Washer Plain	2	2	
11	30 1910 35	Spring	1	1	
12	JB 1610 02	Pin Brake Rod	1	1	
13	30 1910 36	Nut Brake Adjuster	1	1	
14	JW 1220 04	Rod Torque	1	1	
15	DH 1510 29	Step Bolt Torque Rod	1	1	
16	39 1540 11	Plain Washer	1	1	
17	39 0789 12	Spring Washer	2	2	
18	39 0694 15	Hex. Lock Nut M8 x 1.25	1	1	
19	39 0807 08	Split Pin	2	2	
20	30 1510 95	Bolt Hex.	1	1	
21	39 0708 15	Nut Hex. M10 X 1.25	1	1	

HANDLE BAR

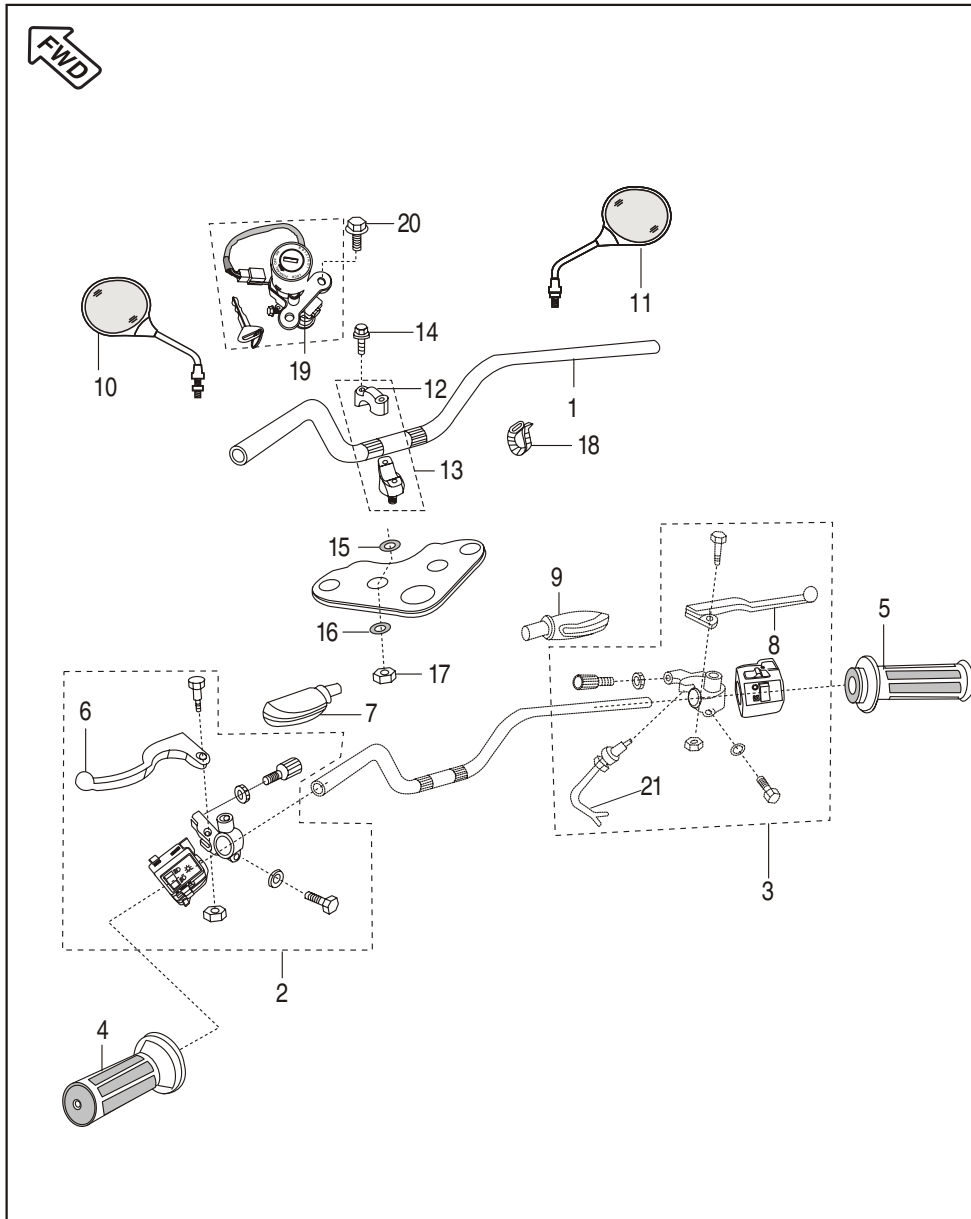

No.	Part No.	Description	Qty		Remarks
			KS	ES	
1	PF 1510 00	Handle Bar	1	1	
2	PF 4014 00	Control Switch LH	1	1	
3	PF 4014 02	Control Switch RH	1	--	
	PF 4014 01	Control Switch RH	--	1	
4	JV 1610 01	Grip LH	1	1	
5	JV 1610 02	Grip Assly. RH	1	1	
6	PF 1610 03	Lever Control LH	1	1	
7	PF 1612 03	Boot for Lever LH	1	1	
8	PF 1610 04	Lever Control RH	1	1	
9	PF 1612 05	Boot for Lever RH	1	1	
10	PF 2316 00	Mirror LH	1	1	
11	PF 2316 01	Mirror RH	1	1	
12	FD 1810 30	Holder Handle Upper	2	2	
13	FD 1810 31	Holder Handle Lower	2	2	
14	39 1074 04	Bolt Flanged Small	4	4	
15	DF 1810 91	Damper Handle Upper	2	2	
16	DF 1810 92	Damper Handle Lower	2	2	
17	39 0422 15	Nut- Nyloc M-10	2	2	
18	30 1910 48	Band	2	2	
19	DF 1810 24	Lock Set- Steering ,P.Tank, Side Cover, DC IGN	1	1	
20	39 1943 04	Bolt Flanged	2	2	
21	JV 4014 09	Front Brake Switch			

Front Fork

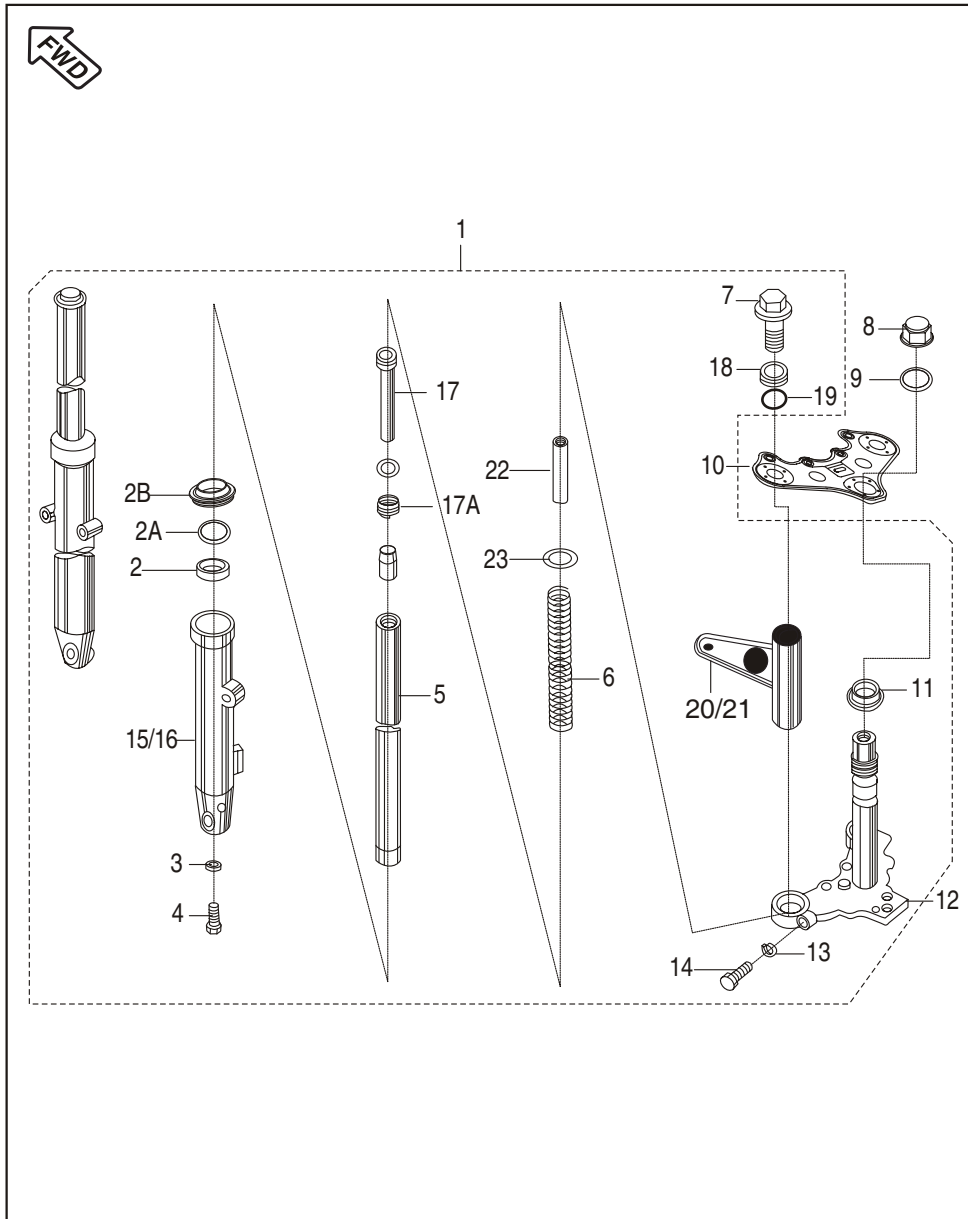

No.	Part No.	Description	Qty		Remarks
			KS	ES	
1	PF 1210 01	Front Fork Assly	1	1	
2	DL 1810 80	Front Fork Oil Seal	2	2	
2A	31 1811 08	Ring Snap	2	2	
2B	DD 1810 32	Seal Dust	2	2	
3	30 1810 26	Gasket	2	2	
4	30 1810 25	socket Head Bolt	2	2	
5	PF 1210 10	Fork Pipe Inner	2	2	
6	DE 1810 31	Spring Front Fork	2	2	
7	31 1811 20	Bolt Fork with Washer	2	2	
8	FD 1810 12	Cap Nut Fork	1	1	
9	DF 1810 89	Plain Washer	1	1	
10	DF 1810 77	Holder Fork Upper	1	1	
11	30 1810 09	Bearing Cone Fork	1	1	
12	DF 1810 83	Holder Assly Fork Under	1	1	
13	39 0789 12	Spring Washer	2	2	
14	39 1813 04	Bolt M10X1.25	2	2	
15	DD 1810 31	Pipe Left Fork Outer	1	1	
16	DD 1810 34	Pipe Right Fork Outer	1	1	
17	DE 1810 33	Cylinder Fork	2	2	
17A	31 1810 99	Spring front fork- Two Pitch	2	2	
18	DF 1810 85	Seat Fork Spring	2	2	
19	30 1810 29	O Ring	2	2	
20	PF 1210 02	Lamp Shade LH	1	1	
21	PF 1210 03	Lamp Shade RH	1	1	
22	PF 1210 11	Collar	2	2	
23	DM 1810 10	Washer	2	2	

PAINTED PARTS

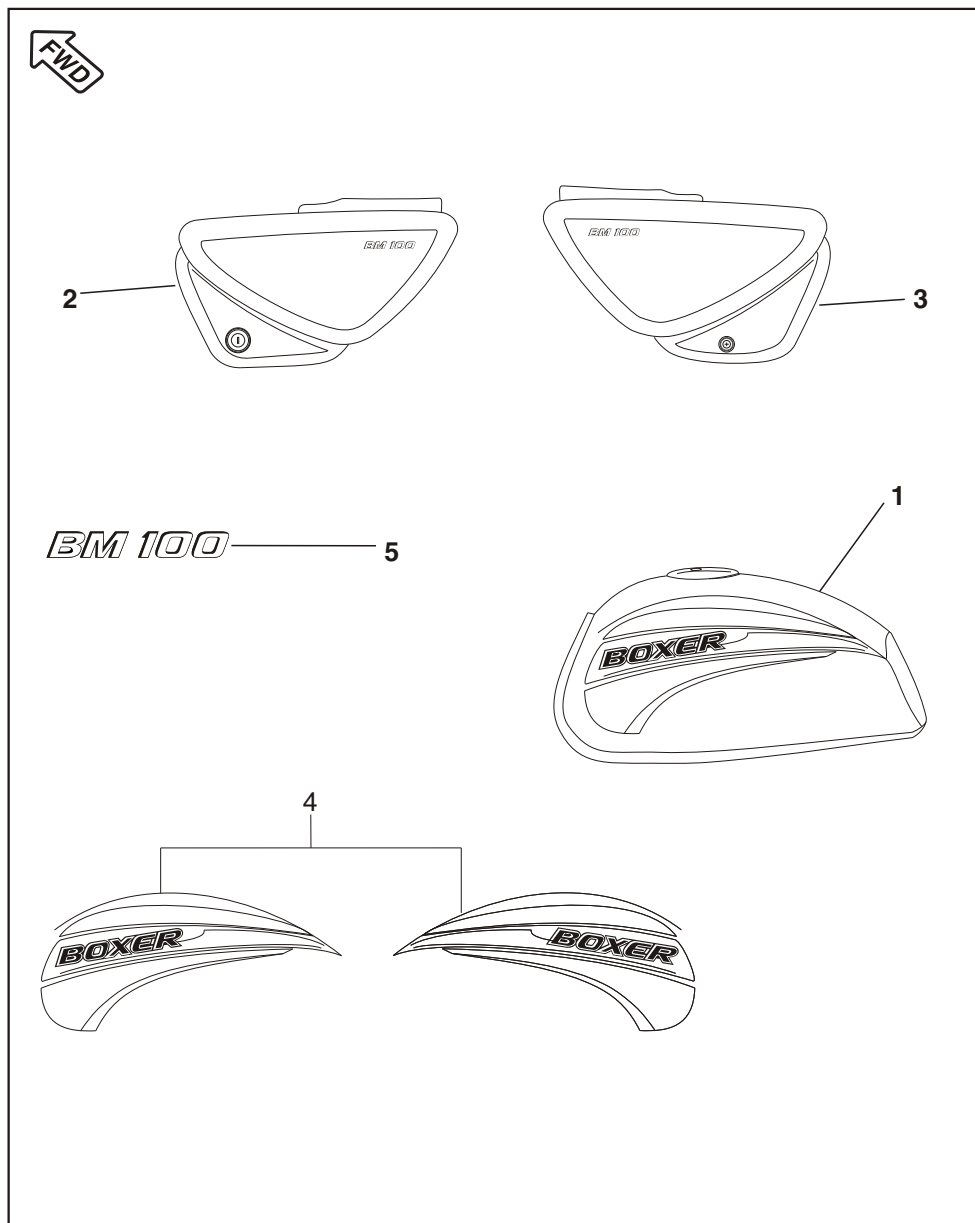

No.	Part No.	Description	Qty		Remarks
			KS	ES	
1	PF 7102 X3	Fuel Tank Ebony Black Decal	1	1	
	PF 7102 3E	Fuel Tank Electron Blue Decal	1	1	
	PF 7102 3F	Fuel Tank Flame Red Decal	1	1	
2	PF 7303 X3	Side Cover LH Ebony Black Decal	1	1	
	PF 7303 3E	Side Cover LH Electron Blue Decal	1	1	
	PF 7303 3F	Side Cover LH Flame Red Decal	1	1	
3	PF 7304 X3	Side Cover RH Ebony Black Decal	1	1	
	PF 7304 3E	Side Cover RH Electron Blue Decal	1	1	
	PF 7304 3F	Side Cover RH Flame Red Decal	1	1	
4	36 PF00 15	Kit Decal Tank Red	1	1	Ref. Page No. 93
	36 PF00 16	Kit Decal Tank Blue	1	1	Ref. Page No. 93
	36 PF00 17	Kit Decal Tank Black	1	1	Ref. Page No. 93
5	36 PF00 29	Kit Decal Side Cover Red (BM100)	1	1	Ref. Page No. 92
	36 PF00 30	Kit Decal Side Cover Blue (BM100)	1	1	Ref. Page No. 92
	36 PF00 31	Kit Decal Side Cover Black (BM100)	1	1	Ref. Page No. 92

Fittings - Petrol Tank, Side Covers & Cover Seat

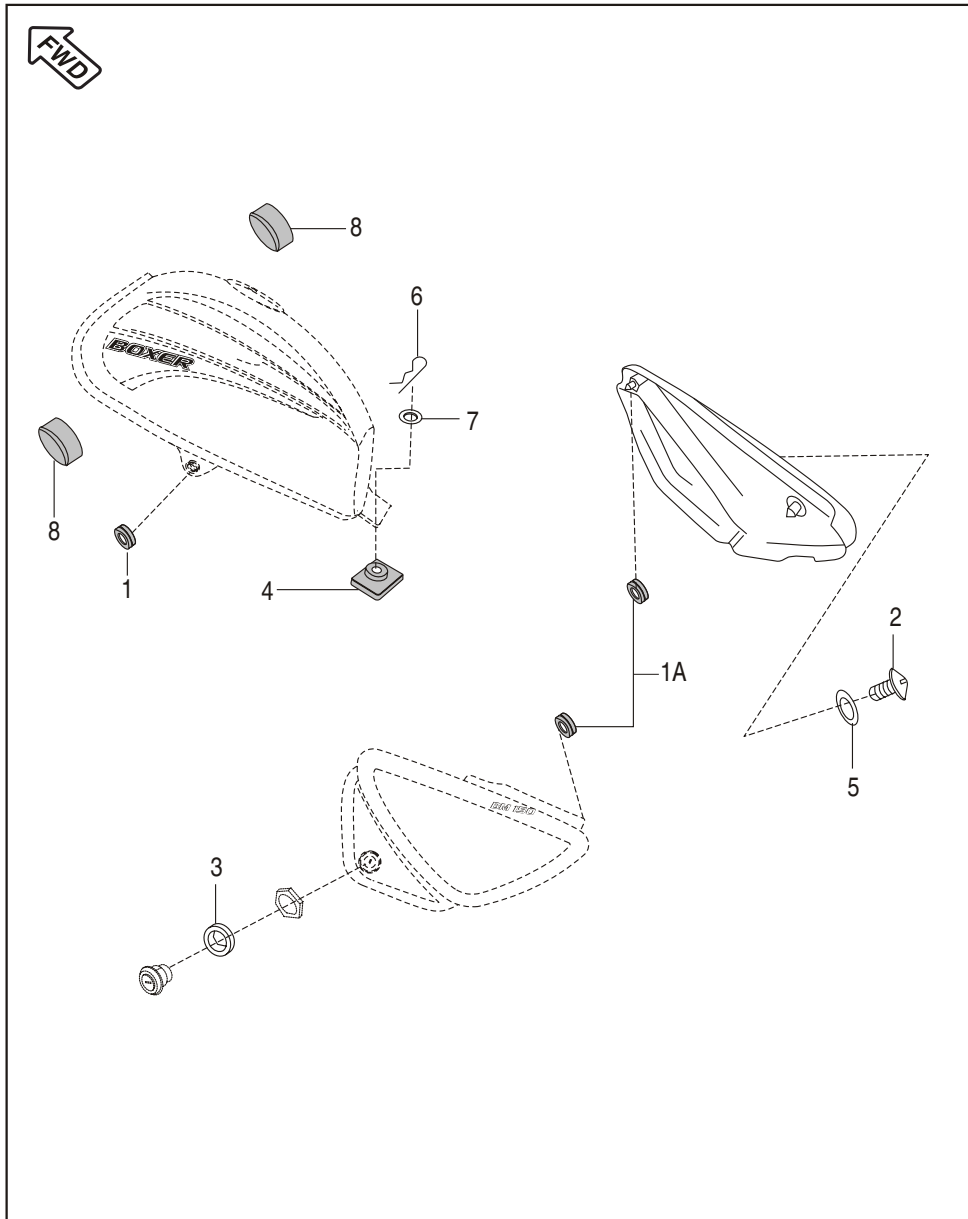

No.	Part No.	Description	Qty		Remarks
			KS	ES	
1	DS 1410 12	Grommet Side Cover Front	2	2	
1A	DH 1611 33	Grommet Side Cover Rear	2	2	
2	DG 1611 21	Screw	1	1	
3	DU 1611 02	Damper	1	1	
4	JV 1710 01	Damper Tank Rear	1	1	For Tank
5	39 1789 24	Washer Nylon	3	3	
6	39 0983 08	Pin Snap	1	1	
7	39 1054 11	Plain Washer	1	1	
8	DJ 1410 08	Damper Front	2	2	For Tank Mounting

Petrol Tank, Cap Tank and Gauge Fuel

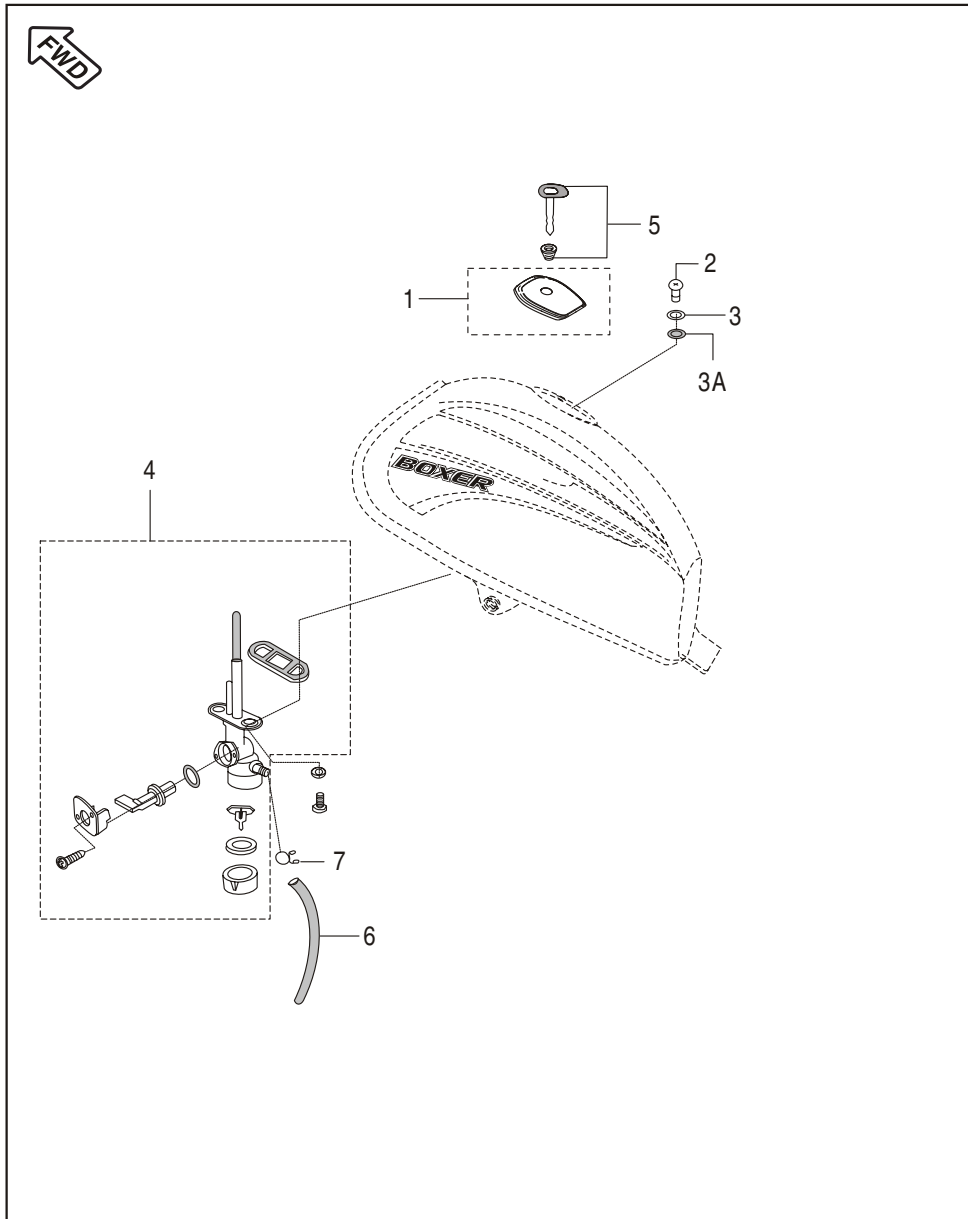

No.	Part No.	Description	Qty		Remarks
			KS	ES	
1	DS 1410 09	Cap Assly. Tank	1	1	
2	39 0761 01	Screw Pan Cross	2	2	
3	39 2179 24	Washer	2	2	
3A	30 1410 31	'O' Ring	2	2	
4	PF 1718 00	Fuel Tap	1	1	
5	DF 1810 24	4 in 1 Lock Set with Key	1	1	
6	PF 1718 03	Pipe Fuel	1	1	Cock to Carburettor
7	30 1410 15	Pipe Clip	2	2	

SIDE COVERS

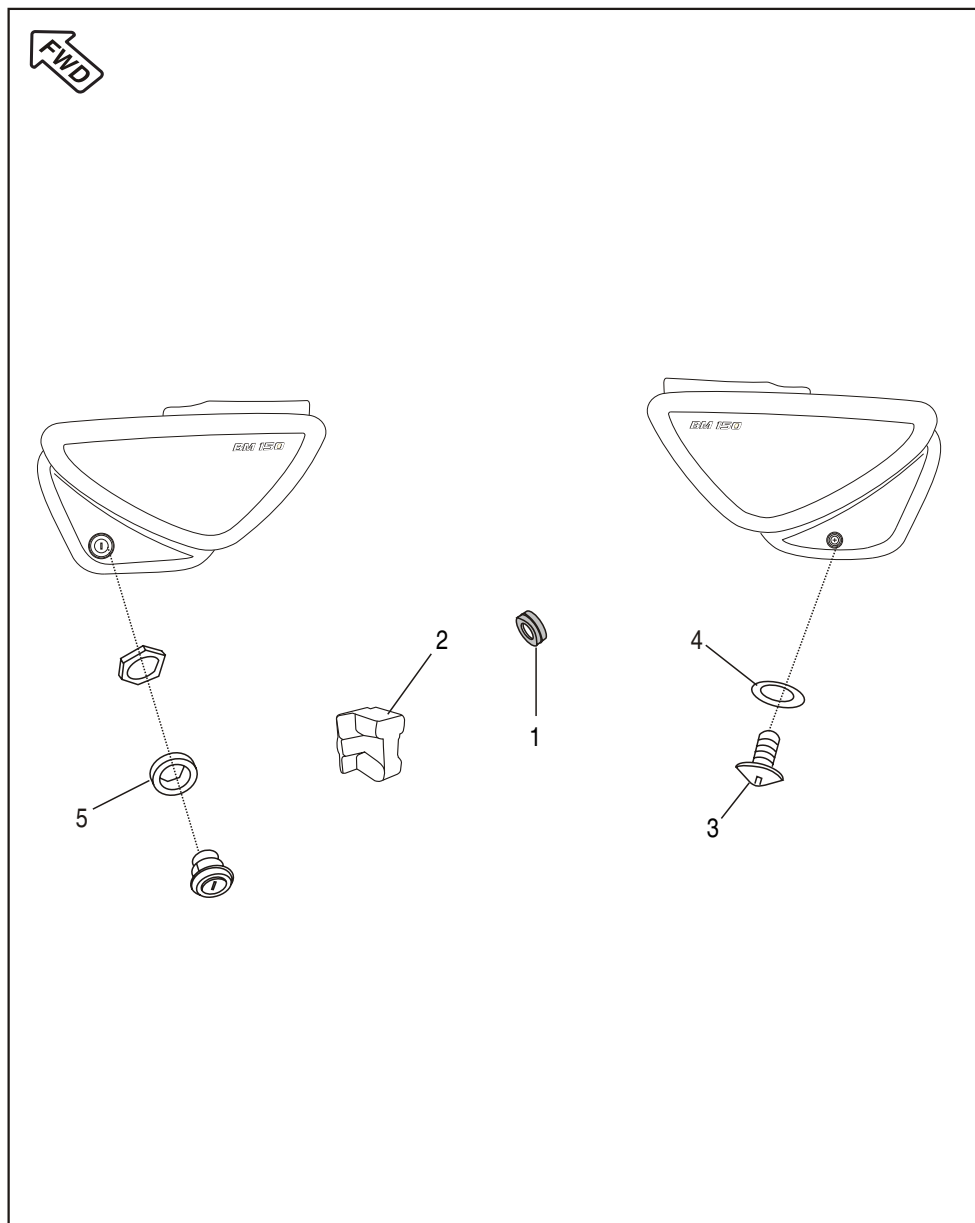

No.	Part No.	Description	Qty		Remarks
			KS	ES	
1	30 1611 69	Grommet Side Cover Rear RH	1	1	
2	DH 1611 33	Grommet Side Cover Rear LH	1	1	
3	DG 1611 21	Screw	1	1	
4	39 1789 24	Washer Nylon	1	1	
5	DU 1611 02	Damper for Lock	1	1	

Chain Case

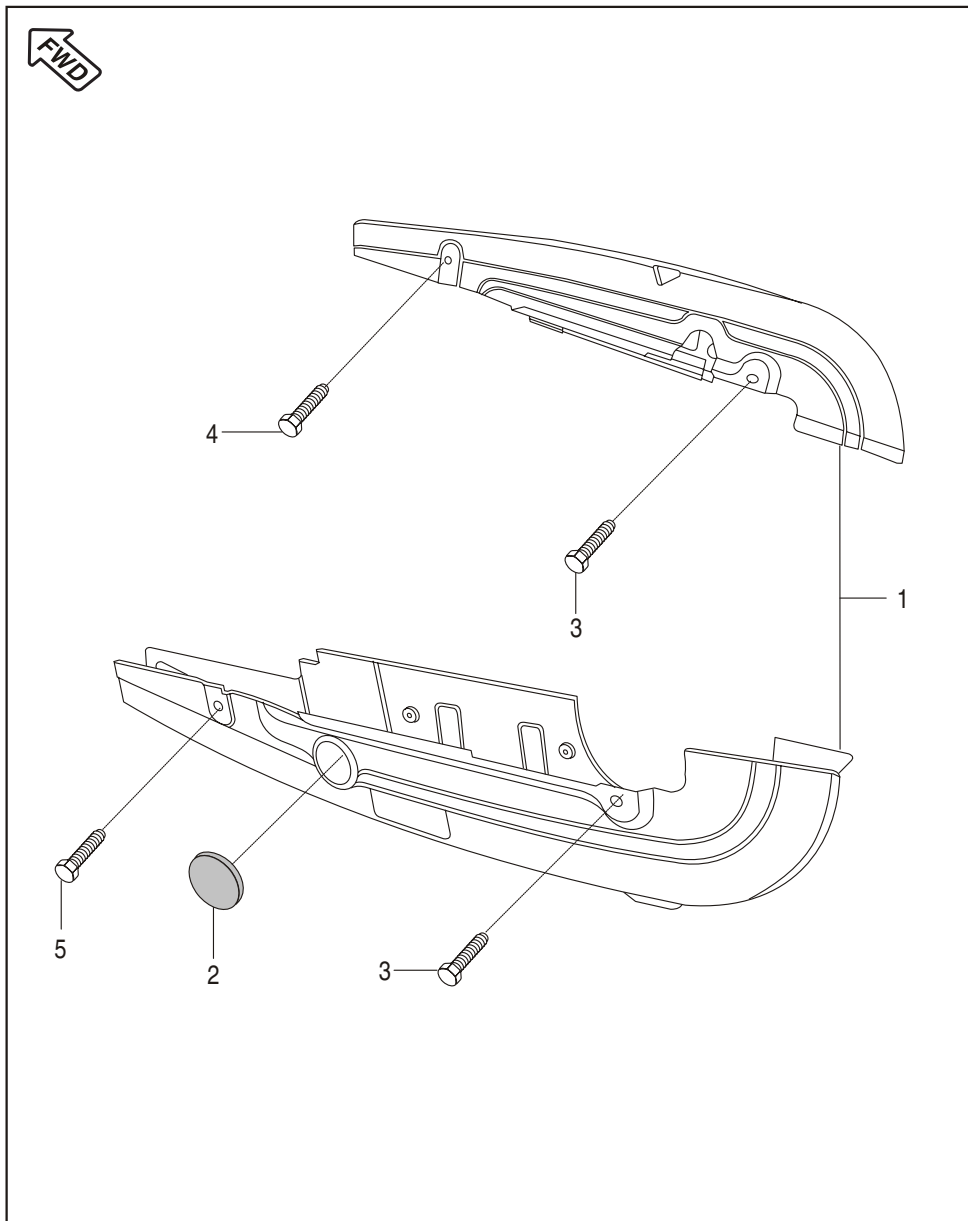

No.	Part No.	Description	Qty		Remarks
			KS	ES	
1	36 PF00 11	Kit Chain Case	1	1	Refer Page No. 92
2	15 1610 69	Rubber Cap	1	1	
3	JB 1812 39	Bolt M6	2	2	
4	JB 1812 20	Flange Bolt M6 X 1P X 62 L	1	1	
5	JB 1812 21	Flange Bolt M6 X 1P X 50 L	1	1	

METER ASSLY

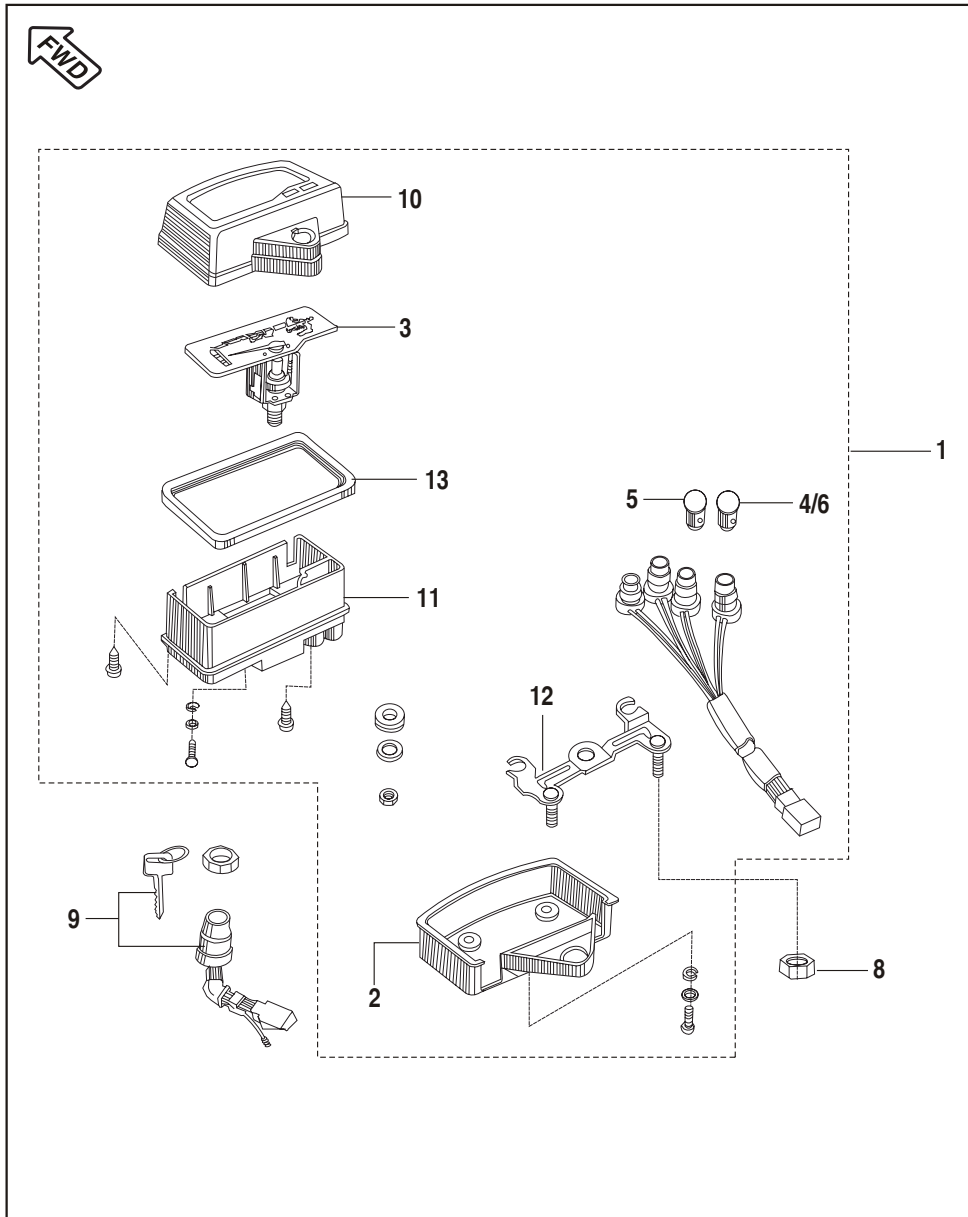

No.	Part No.	Description	Qty		Remarks
			KS	ES	
1	31 1910 12	Meter Assly/ Lamp	1	1	
2	31 1910 21	Cover Meter Lower Black	1	1	
3	31 1910 18	Speedometer	1	1	
4	30 2010 29	Lamp 12V 4W	1	1	
5	30 2011 29	Lamp 12V 2W	2	2	
6	30 2010 84	Lamp 12V 4W	1	1	
7	DF 1810 24	Lock Set (4 in 1)	1	1	N.I.
8	39 0798 15	Nut	1	1	
9	DF 1810 24	Lock Set Steering, P.Tank, Side cover, DC Ing.	1	1	
10	31 1910 17	Cover meter case upper	1	1	Black
11	31 1910 20	Cover (white)	1	1	
12	31 1910 14	Bracket Meter	1	1	
13	31 1910 19	Gasket Rubber	1	1	

Head Lamp Assly

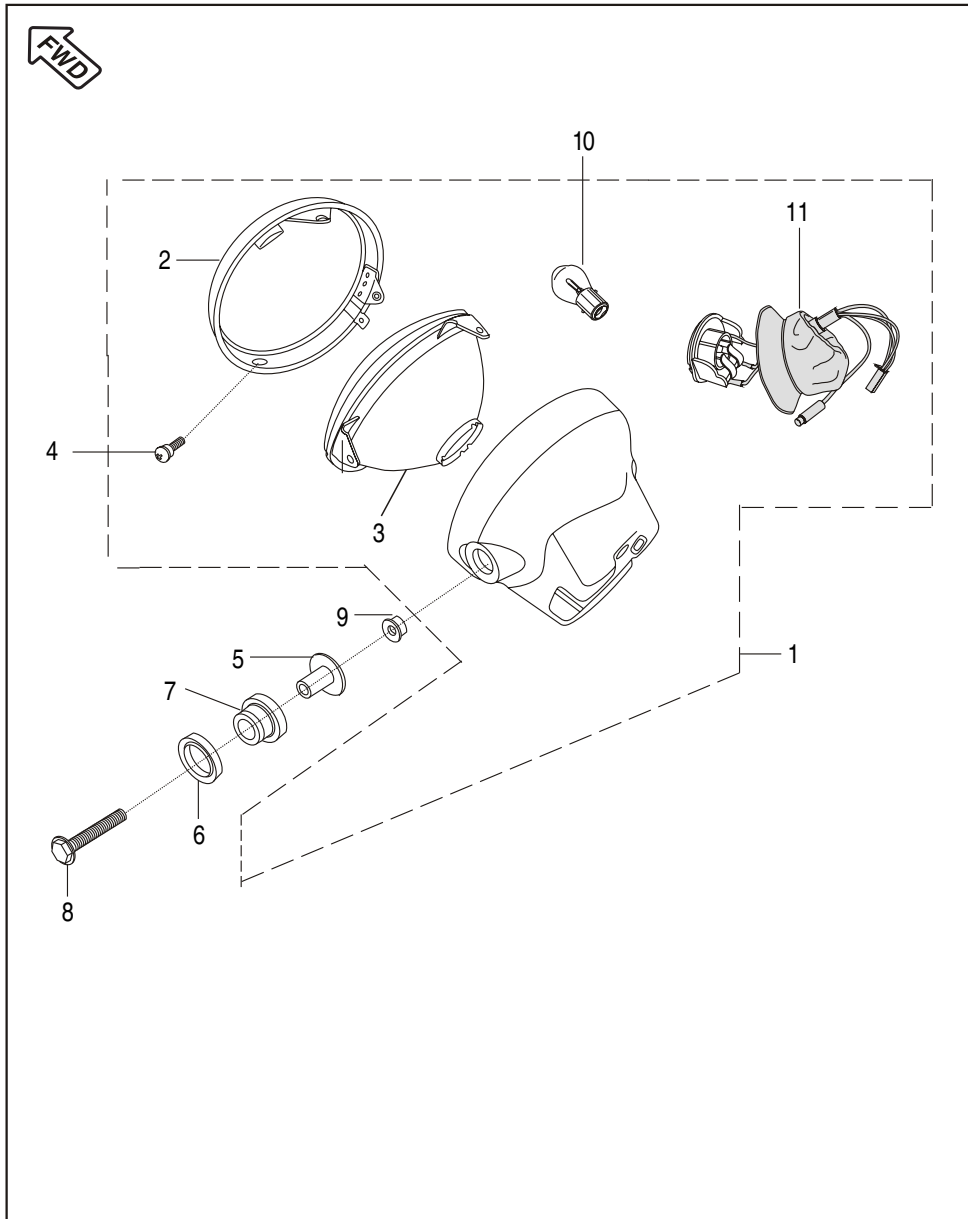

No.	Part No.	Description	Qty		Remarks
			KS	ES	
1	PF 4010 00	Head light assly	1	1	
2	DJ 2010 46	Head Light Rim	1	1	
3	DJ 2010 51	Reflector with Lens	1	1	
4	DU 2010 29	Special Screw	2	2	
5	DS 2010 19	Collar	2	2	
6	DS 2010 20	Damper I	2	2	
7	DS 2010 21	Damper II	2	2	
8	39 2582 04	Flange Bolt M-8 L 35	2	2	
9	39 1970 15	Flange Nut M-8	2	2	
10	CL 2010 23	Lamp 12 V 35/35 W HS1	1	1	
11	DF 2010 58	Lamp Holder (Socket) Assly.	1	1	

Control Cables

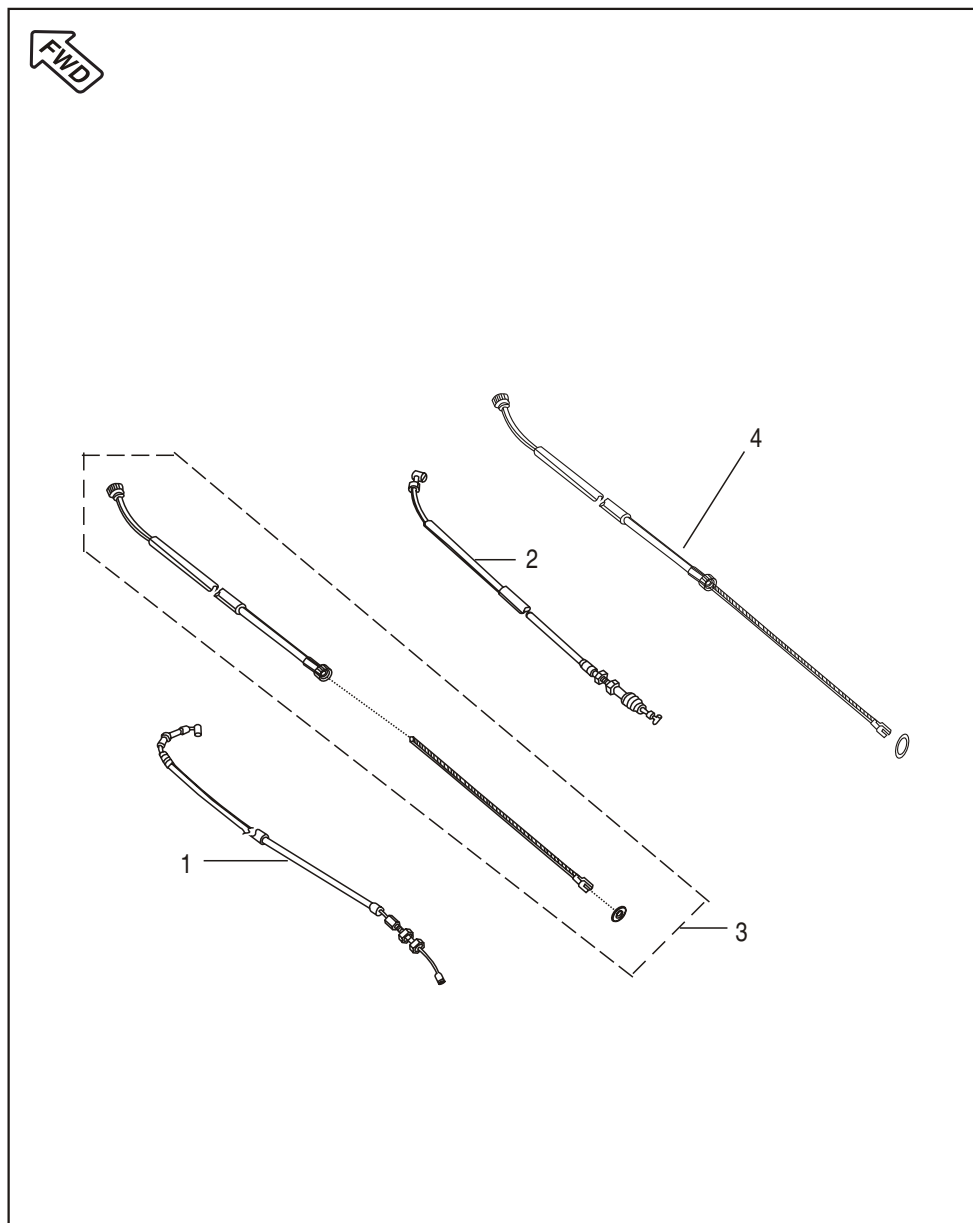

No.	Part No.	Description	Qty		Remarks
			KS	ES	
1	PF 1612 01	Cable Throttle	1	1	
2	PF 1612 04	Clutch Cable	1	1	
3	PF 1612 02	Brake Cable	1	1	
4	DZ 1910 14	Cable Speedo Meter	1	1	

Turn Signal Lamps

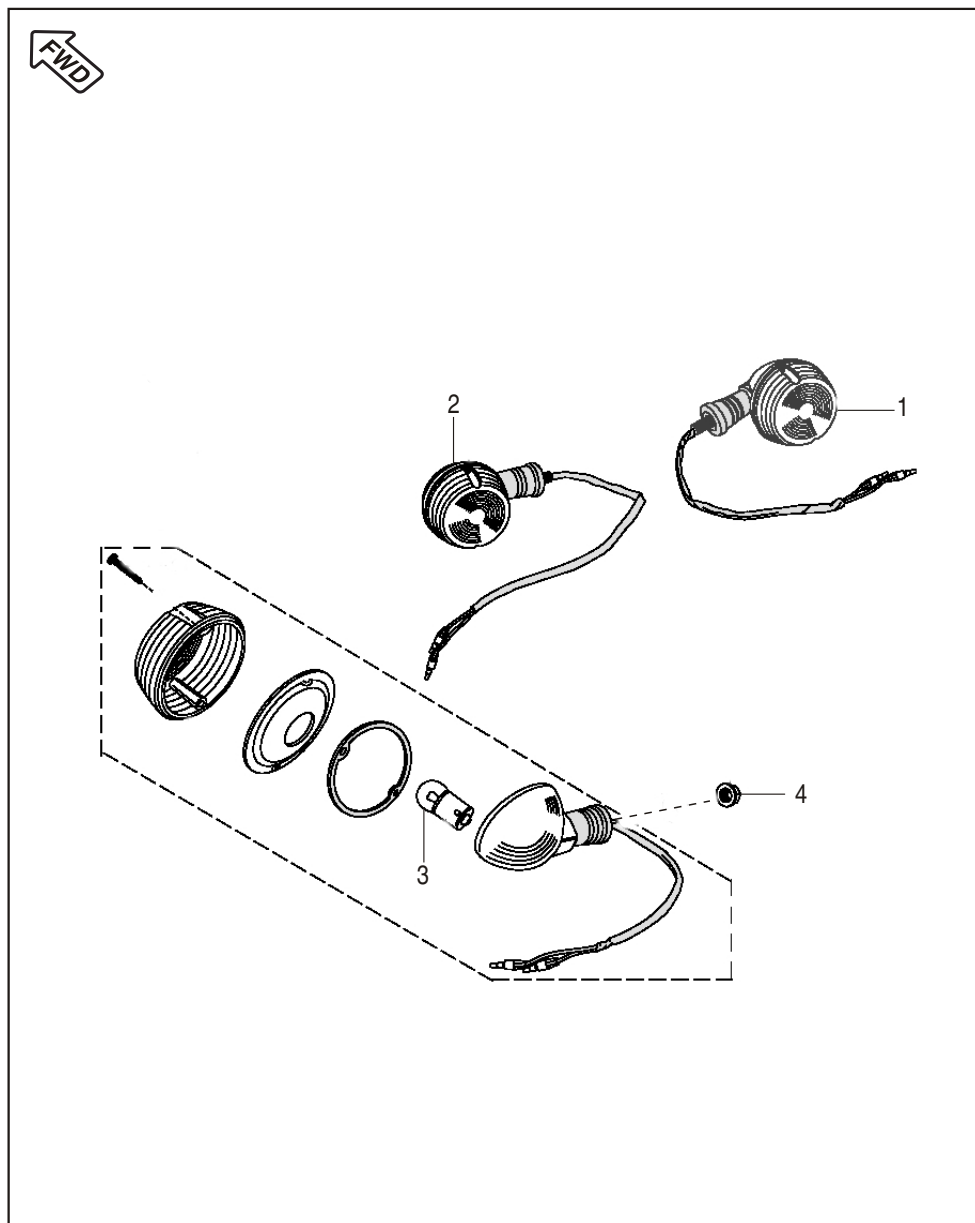

No.	Part No.	Description	Qty		Remarks
			KS	ES	
1	DU 2010 14	Lamp -Dir. Indicator :FR-LH & RR-RH	2	2	
2	DU 2010 12	Lamp -Dir. Indicator :FR-RH & RR-LH	2	2	
3	06 2010 83	Lamp 12 V 10 W	4	4	
4	39 1225 15	Hex. Nut Flange M-10	4	4	

Tail Lamp Assly & Number Plate

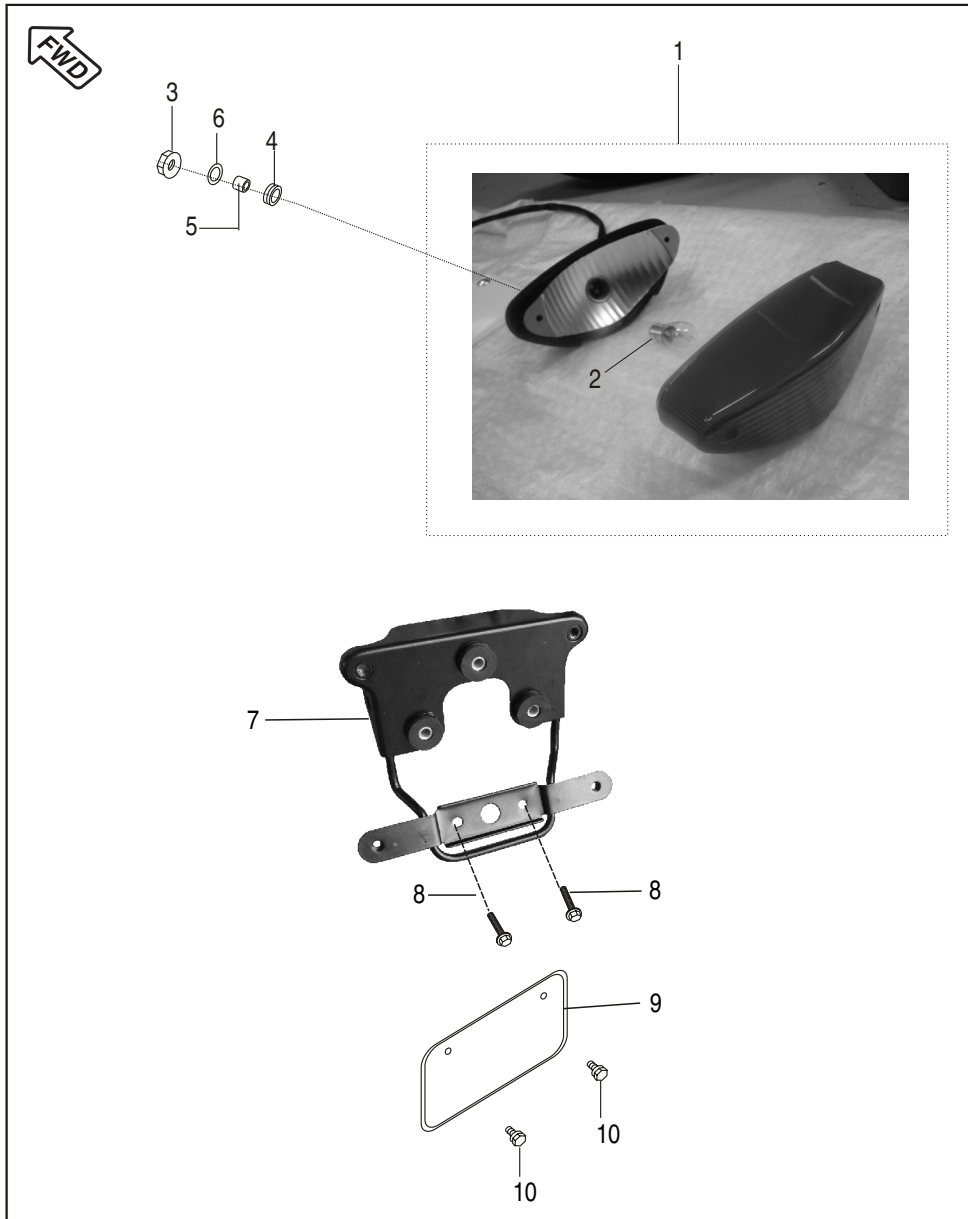

No.	Part No.	Description	Qty		Remarks
			KS	ES	
1	DF 2011 38	Tail Light Assly. with lamp	1	1	For Mtg. Tail light
2	31 2010 28	Lamp 12 V, 10/5W	1	1	
3	39 2430 15	Hex Nut. / Flange	2	2	
4	DD 2010 11	Damper	2	2	
5	31 2010 01	Collar	2	2	
6	39 2429 11	Plain Washer	2	2	
7	PF 2314 01	Bracket Tail Light Assly	1	1	
8	39 1956 04	Bolt Flange Small (for No. Plate)	2	2	
9	DF 1612 52	Plate No. Rear Black	1	1	
10	39 2765 01	Screw Truss M6	2	2	

Seat Assly & Grip Frame

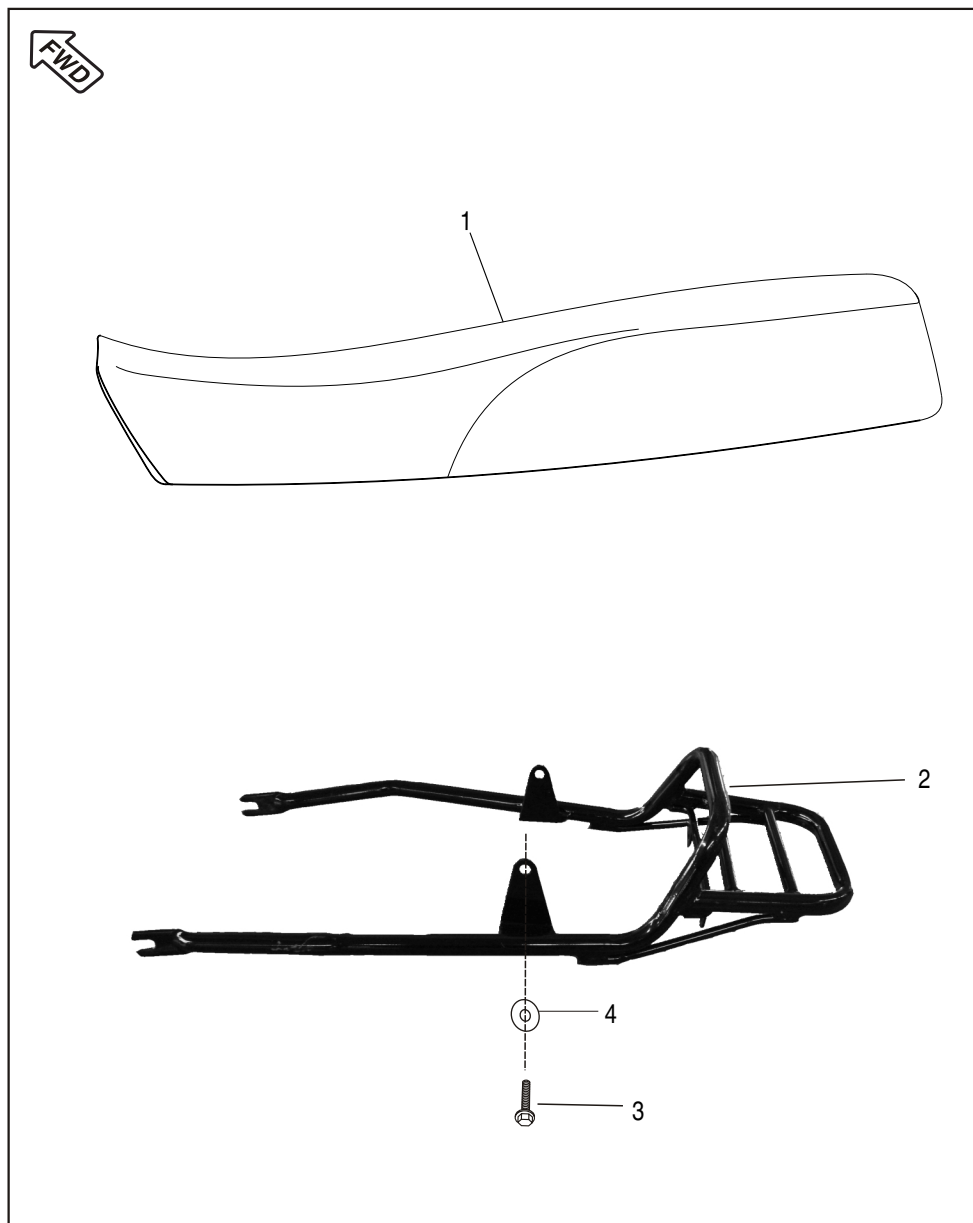

No.	Part No.	Description	Qty		Remarks
			KS	ES	
1	JV 1910 01	Seat assly. complete	1	1	
2	PF 2314 05	Grip Frame	1	1	
3	39 1556 04	Hex. Head Bolt / Flange M8	2	2	
4	39 1211 11	Washer Plain	2	2	

Electric Equipments

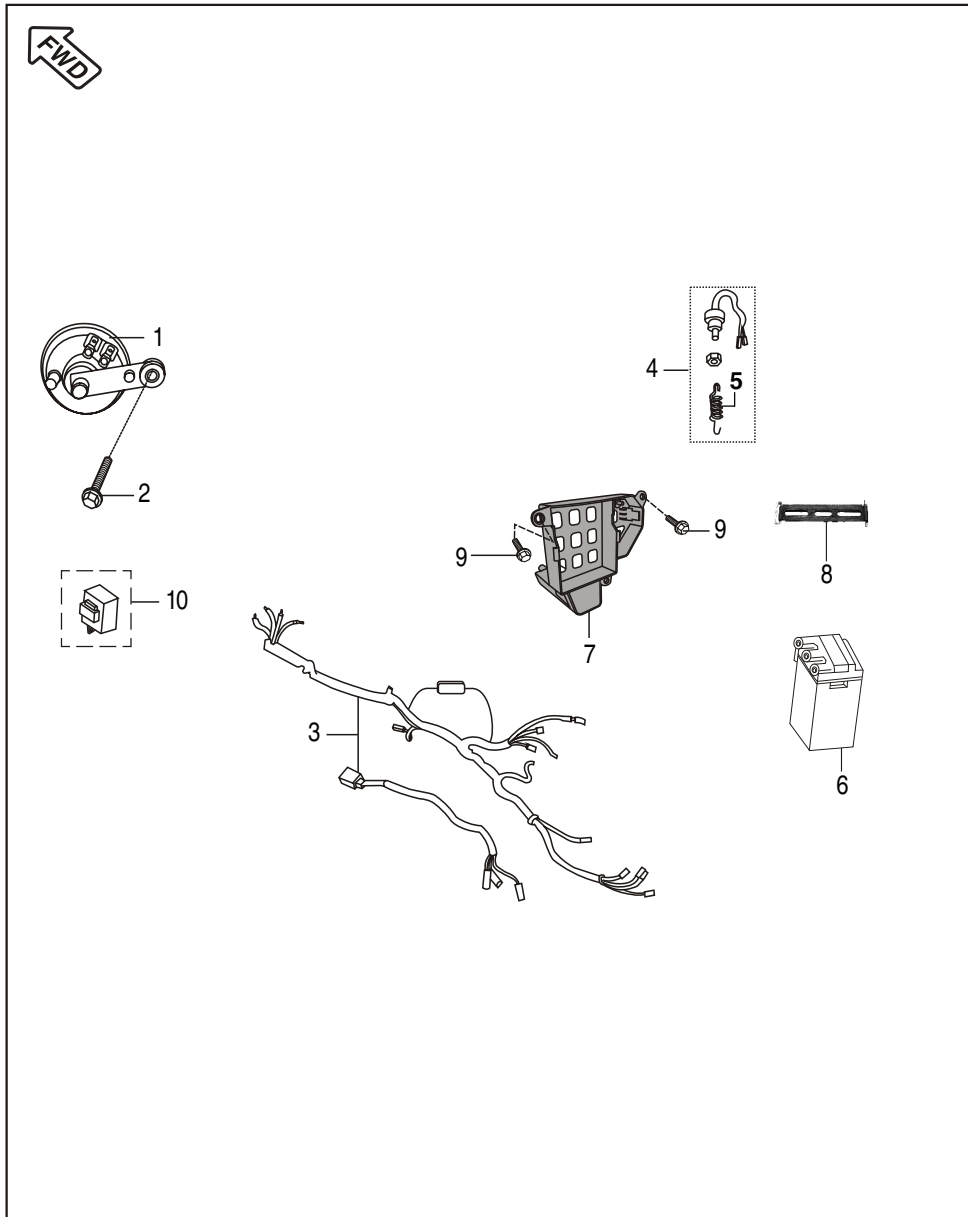

No.	Part No.	Description	Qty		Remarks
			KS	ES	
1	JV 4016 00	Horn	1	1	
2	39 1689 04	Flange Bolt M8	1	1	
3	PF 4022 04	Wiring Harness	1	--	
	PF 4022 01	Wiring Harness	--	1	
4	31 2010 79	Rear Brake Switch	1	1	
5	PF 4014 03	Spring Brake Switch	1	1	
6	31 2010 27	BATTERY (2.5 Ah)	1	--	
	DS 2010 82	Battery MF Dry Charged 5Ah	--	1	
7	JV 4018 01	Case Battery	1	1	
8	JV 4018 02	Band Battery	1	--	
	JA 4018 01	Band Battery	--	1	
9	DS 1612 24	Stepped Bolt	3	3	
10	DS 2010 25	Assly D.C. Flasher	1	1	

Tool Kit

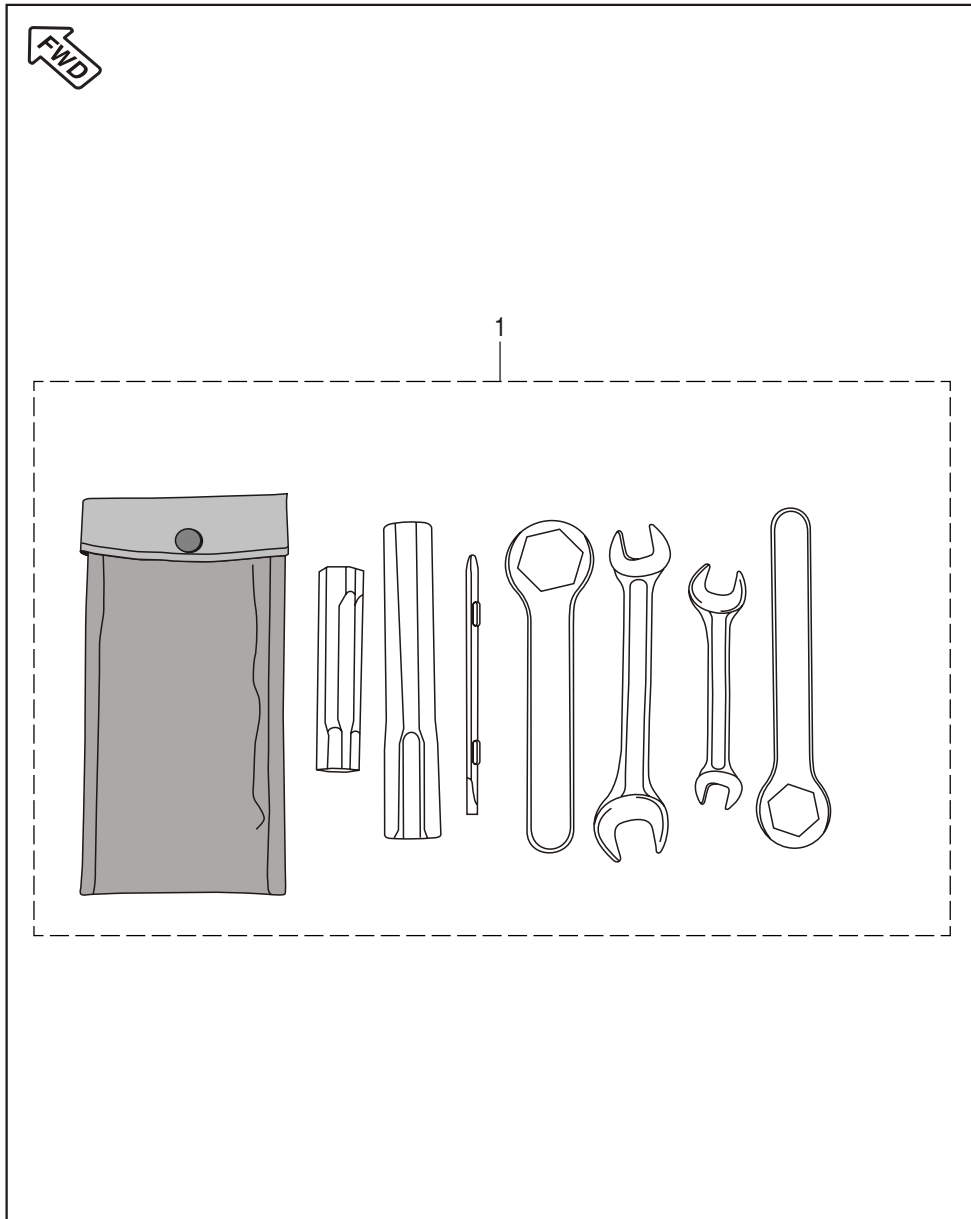

No.	Part No.	Description	Qty		Remarks
			KS	ES	
1	DM 221013	Tool Kit with Value Engineered Tools	1	1	

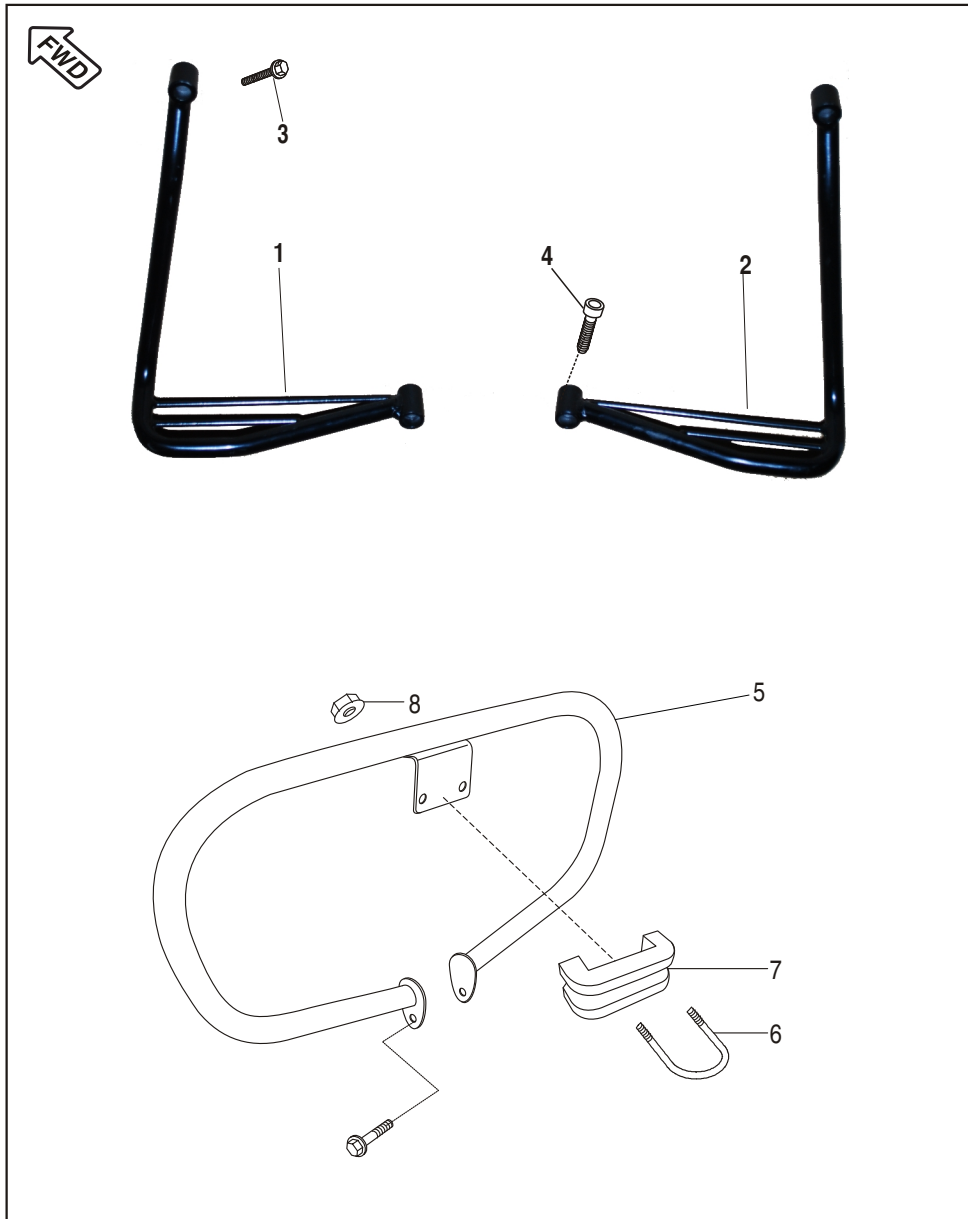

Accessories

No.	Part No.	Description	Qty		Remarks
			KS	ES	
1	PF 1130 08	Footrest Third LH	1	1	
2	PF 1130 09	Footrest Third RH	1	1	
3	39 1298 04	Screw Hex. Socket M8x1.25x35	2	2	
4	JB 2312 06	Bolt Socket Head	2	2	
5	PF 2312 01	Leg Guard	1	1	
6	JA 2312 01	Hook Leg Guard	1	1	
7	JA 2312 02	Spacer Leg Guard	1	1	
8	39 0798 15	Nut Hex with Falnge M6	2	2	
9	36 JW00 13	Leg Guard Hardware Kit (Kit consists of Sr. No. 6,7,8)	1	1	Ref. Page. No.

Kit List

Sr No	Kit Part No.	Kit Description	Consisting of Following Parts		
			Part No.	Description	Qty/Kit
1	36314001	Bearing Cone Kit	DH181025	Bearing cone	1
			DH181026	Bearing race	1
			DH181024	Upper bearing race	1
2	36DU1007	Boss Kick Set	30101233	Boss Kit	1
			30101234	Spring	1
			30101236	Ball Steel	1
			30101235	Pin	1
			39085517	E - Type Clip	1
3	36JA0003	Kit Valve Repair Kit	28101129	Spring - Seat	2
			39201719	Seal - Oil	2
			JA511202	Spring Valve	2
			JA511203	Retainer Valve Spring	2
			DG101029	Collet	4
4	36JW0014	Kit Starter Clutch Repair	39243704	Bolt - Hex. Socket Head Cap:- M6	3
			JA621411	Bush Spring Starter Clutch	5
			DH101163	Roller Clutch	5
			DH101164	Spring Starter Clutch	5
			DJ101109	Bush for Spring Starter	5
5	36JZ0023	Kit Primary Drive & Driven	PF551401	Clutch HSG Assly Comp	1
			JZ531006	Gear Primary Drive	1
6	36JZ0037	Kit Friction Plate	JZ551416	Plate Friction	5
7	36PA0002	Kit Guide Cam Chain	JB541004	Guide Cam Chain (Slack Side)	1
			JB521007	Guide Cam Chain (Tight Side)	1

Kit List

Sr No	Kit Part No.	Kit Description	Consisting of Following Parts		
			Part No.	Description	Qty/Kit
8	36PA0004	Kit Valve	JB511200	Valve Intake	1
			JB511201	Valve Exhaust	1
9	36PA0013	Kit Idling Screw	JB581241	Screw Stop PTE16 XCD125 Carb	1
			JB581240	O-ring Adjuster Screw	1
			JB581242	Spring Screw Stop	1
10	36PA0015	Kit Carb. Gasket - O ring	JB581231	Gasket Float Chamber	1
			JB581239	Gasket Throttle Cap	1
			JB581240	Spring Adjuster Screw	3
			JB581269	Seal O-ring FCB PTE16	1
11	36PF0011	Case Chain Kit	PF181202	Case Chain Upper Assly.	1
			PF181200	Case Chain Lower Assly.	1
12	36PF0027	Kit Cyl. Block/Piston Assly	PF521001	Cylinder Block	1
			PF521200	Assembly Piston	1
13	36PF0028	Kit Piston Ring Set	JB521207	Ring Piston Top	1
			JB521208	Ring Piston Second	1
			PF521204	Ring Piston Oil	1
14	36PF0029	Kit Decal Side Cover Red	PF233019	Decal Side Cover (Red) LH	1
			PF233020	Decal Side Cover (Red) RH	1
15	36PF0030	Kit Decal Side Cover Blue	PF233021	Decal Side Cover (Blue) LH	1
			PF233022	Decal Side Cover (Blue) RH	1
16	36PF0031	Kit Decal Side Cover Black	PF233023	Decal Side Cover (Black) LH	1
			PF233024	Decal Side Cover (Black) RH	1

Kit List

Sr No	Kit Part No.	Kit Description	Consisting of Following Parts		
			Part No.	Description	Qty/Kit
17	36PF0015	Kit Tank Decal Red	PF233006	Decal Tank LH Red	1
			PF233007	Decal Tank RH Red	1
18	36PF0016	Kit Tank Decal Blue	PF233008	Decal Tank LH Blue	1
			PF233009	Decal Tank RH Blue	1
19	36PF0017	Kit Tank Decal Black	PF233010	Decal Tank LH Black	1
			PF233011	Decal Tank RH Black	1
20	36PF0032	Kit Jet Needle	PF581301	Jet Needle	1
			PF581306	Needle Jet	1
			PF581302	Holder Needle Jet	1
			PF581303	Jet Main	1
			PF581301	Jet Complete	1
21	36PF0033	Kit Air Screw	PF581307	Screw Adjuster	1
			JB581240	O Ring	3
			JB581244	Spring Comp. Coil	1
			JB581245	Washer	1
			JB581246	O Ring	1
22	36PF0034	Kit Valve Throttle	PF581305	Valve Throttle	1
			JB581235	Clip Bar	1
			JB581206	Magnet Holder	1
			JB581249	Spring Complete	1

Kit List

Sr No	Kit Part No.	Kit Description	Consisting of Following Parts		
			Part No.	Description	Qty/Kit

Parts Index

Part Number	Figure No.	Page No.	Part Number	Figure No.	Page No.
01110609	4	48	30181029	19	62
06201083	3	80	30181037	23	62
14151021	4	54	30181038	22	62
15161069	2	72	30191035	11	58
16151066	1	52	30191036	13	58
22150241	4	30	30191038	3	58
22150435	3	48	30191048	18	60
30101096	6	28	30201029	4	74
30101142	4	24	30201084	6	74
30101195	8	26	30201129	5	74
30141015	7	68	31101173	3	12
30141031	3A	68	31151004	3	54
30151011	16	56	31151011	12	54
30151038	13	54	31151014	18	54
30151038	17	56	31151064	19	54
30151041	20	54	31181099	17A	62
30151042	21	54	31181108	2A	62
30151069	11	54	31181120	7	62
30151069	15	56	31191012	1	74
30151075	11	56	31191014	12	74
30151095	20	58	31191017	10	74
30151105	10	54	31191018	3	74
30151105	14	56	31191019	13	74
30161169	1	70	31191020	11	74
30171022	19	50	31191021	2	74
30181009	11	62	31201001	5	82
30181025	4	62	31201027	6	86
30181026	3	62	31201028	2	82

Parts Index

Part Number	Figure No.	Page No.	Part Number	Figure No.	Page No.
31201079	4	86	36PF0037	1	4
31201081	5	22	36PF0038	1	22
36314001	3	44	36PF0039	1	22
36DU1007	3	30	36PF0040	2	20
36JA0003	5	6	39019811	5	58
36JW0014	17	40	39019811	10	58
36JZ0023	7	12	39021111	15	48
36JZ0023	15	28	39024811	6	54
36JZ0037	4	28	39029215	15	46
36PA0002	6	8	39032615	13	48
36PA0004	4	6	39042215	8	50
36PA0013	6	32	39042215	17	60
36PA0015	15	32	39045411	10	46
36PF0007	1	26	39055302	9	46
36PF0008	1	24	39059417	12	8
36PF0011	1	72	39069415	18	58
36PF0014	5	46	39070815	21	58
36PF0015	4	64	39071411	2	46
36PF0016	4	64	39073817	6	30
36PF0017	4	64	39074701	9	22
36PF0027	5	10	39076101	2	68
36PF0028	3	10	39077504	16	54
36PF0029	5	64	39077504	20	56
36PF0030	5	64	39078111	18	46
36PF0031	5	64	39078408	21	50
36PF0032	5	32	39078912	7	46
36PF0033	4	32	39078912	17	58
36PF0034	14	32	39078912	13	62

Parts Index

Part Number	Figure No.	Page No.	Part Number	Figure No.	Page No.
39079708	4	50	39107404	14	60
39079708	8	58	39121111	4	84
39079815	17	54	39122515	4	80
39079815	21	56	39128321	6	4
39079815	8	74	39129804	3	90
39079815	8	90	39150711	17	48
39080115	6	56	39154011	16	58
39080511	7	58	39155604	16	48
39080708	19	58	39155604	3	84
39080808	6	58	39167121	17	24
39081715	8	18	39167404	3	42
39084001	23	54	39168904	2	86
39093915	12	46	39171519	4	22
39098004	10	28	39175904	17	22
39098308	6	66	39177304	13	34
39098717	3	14	39178924	5	66
39099206	2	16	39178924	4	70
39099311	5	30	39181304	14	62
39099906	12	22	39183911	12	48
39099906	20	24	39186420	5	12
39099906	4	38	39194304	11	42
39100006	2	10	39194304	14	48
39100006	6	20	39194304	20	60
39100006	11	22	39195604	8	82
39100120	14	28	39196404	14	20
39104119	3	24	39197015	10	44
39105411	7	66	39197015	9	76
39105711	11	28	39198104	20	14

Parts Index

Part Number	Figure No.	Page No.	Part Number	Figure No.	Page No.
39198820	15	8	39268620	9	56
39201719	6	6	39268720	10	56
39217924	3	68	39270411	7	18
39219019	7	22	39272315	7	44
39222204	8	48	39276501	10	82
39224020	2	56	52JA0027	9	20
39229515	3	36	52JA0028	13	28
39231204	9	44	52JA0029	12	20
39234911	3	46	59040017	11	44
39236615	6	46	59110008	2B	12
39240817	12	30	59120003	2A	12
39242001	11	48	59150014	1	12
39242911	6	82	59200036	3	20
39243015	3	82	59200036	3	22
39243704	5	40	59210024	17	14
39247304	7	48	CB101114	2	36
39248104	22	50	CL201023	10	76
39248415	5	48	CS101128	9	8
39256220	2	22	DD101097	13	30
39256611	24	56	DD111011	9	42
39256711	5	56	DD111012	10	42
39258204	8	76	DD111018	7	42
39260011	3	28	DD111048	8	42
39265912	23	50	DD121181	16	24
39266921	13	8	DD151008	15	54
39268020	1	54	DD151009	14	54
39268120	1A	54	DD151009	18	56
39268320	16	8	DD181031	15	62

Parts Index

Part Number	Figure No.	Page No.	Part Number	Figure No.	Page No.
DD181032	2B	62	DG101418	7	24
DD181034	16	62	DG151022	9	52
DD201011	4	82	DG161121	2	66
DE181031	6	62	DG161121	3	70
DE181033	17	62	DG161124	2	50
DF151003	2	54	DH101048	5	8
DF161102	7	50	DH101163	10	40
DF161242	1	48	DH101380	8	20
DF161245	2	48	DH101380	4	42
DF161252	9	82	DH101387	4	8
DF161413	13	50	DH101392	7	8
DF161426	15	34	DH101509	10	18
DF181024	19	60	DH101781	2	40
DF181024	5	68	DH101784	6	22
DF181024	7	74	DH121038	14	34
DF181024	9	74	DH151029	15	58
DF181077	10	62	DH161066	9	50
DF181083	12	62	DH161121	5	50
DF181085	18	62	DH161133	1A	66
DF181089	9	62	DH161133	2	70
DF181090	2	44	DH161194	14	50
DF181091	15	60	DH171019	25	56
DF181092	16	60	DJ141008	8	66
DF191020	6	48	DJ151033	3	56
DF201058	11	76	DJ151035	4	56
DF201138	1	82	DJ151036	13	46
DG101029	3	6	DJ151037	14	46
DG101339	11	18	DJ151047	16	46

Parts Index

Part Number	Figure No.	Page No.	Part Number	Figure No.	Page No.
DJ181115	4	44	DS151053	12	52
DJ201046	2	76	DS151067	8	56
DJ201051	3	76	DS151076	13	56
DK151094	12	56	DS161150	9	26
DL181080	2	62	DS161224	9	86
DM151025	5	52	DS191035	4	58
DM151027	14	52	DS201019	5	76
DM151028	7	52	DS201020	6	76
DM151029	4	52	DS201021	7	76
DM221013	1	88	DS201025	10	86
DP101269	6	24	DS201082	6	86
DP121025	7	2	DU101213	19	14
DP121025	8	34	DU151005	5	54
DP161163	20	50	DU151025	2	52
DP161170	17	50	DU151026	3	52
DP171006	17	46	DU151031	7	54
DS101117	8	30	DU161102	3	66
DS101154	6	12	DU161102	5	70
DS101215	8	24	DU201012	2	80
DS101276	3	8	DU201014	1	80
DS121126	7	34	DU201029	4	76
DS141009	1	68	DZ151012	8	54
DS141012	1	66	DZ151027	9	54
DS151009	10	52	DZ191014	4	78
DS151010	11	52	FD101078	3	38
DS151046	8	52	FD181012	8	62
DS151047	13	52	FD181030	12	60
DS151049	6	52	FD181031	13	60

Parts Index

Part Number	Figure No.	Page No.	Part Number	Figure No.	Page No.
JA113201	3	50	JA531011	14	8
JA113202	6	50	JA531012	8	12
JA113402	6	44	JA531015	9	12
JA113403	8	44	JA541005	8	22
JA121003	11	46	JA541005	6	26
JA131606	22	54	JA541010	5	20
JA231201	6	90	JA541011	4	20
JA231202	7	90	JA541012	13	20
JA351602	11	40	JA541016	2	38
JA351604	8	40	JA541028	13	42
JA351606	9	40	JA541034	10	22
JA351608	12	40	JA541205	3	26
JA351609	13	40	JA541211	11	24
JA351618	14	40	JA541212	13	24
JA351619	16	40	JA541225	12	24
JA351624	15	40	JA541233	7	26
JA351626	9	40	JA541236	9	24
JA351627	11	40	JA541237	10	24
JA401801	8	86	JA551002	4	14
JA511011	6	2	JA551004	7	14
JA511011	9	34	JA551008	15	14
JA511028	2	4	JA551009	16	14
JA511204	2	6	JA551406	2	28
JA511211	1	6	JA551420	12	28
JA511216	2	8	JA561002	3	16
JA521018	10	8	JA561207	4	18
JA521019	11	8	JA561208	5	18
JA521019	19	24	JA561209	6	18

Parts Index

Part Number	Figure No.	Page No.	Part Number	Figure No.	Page No.
JA561211	12	18	JB521211	4	10
JA581005	3	34	JB531021	10	12
JA581006	4	34	JB551406	9	28
JA581009	5	34	JB551408	5	28
JA581011	12	34	JB551411	7	28
JA581012	6	34	JB581001	2	34
JA581013	11	34	JB581001	10	34
JA581406	5	4	JB581202	10	32
JA621001	7	30	JB581204	11	32
JA621002	9	30	JB581229	7	32
JA621006	11	30	JB581230	8	32
JA621201	1	30	JB581232	9	32
JA621206	2	30	JB581237	2	32
JA621402	4	40	JB581238	3	32
JA621406	6	40	JB581256	16	32
JA621410	3	40	JB581259	13	32
JA621414	1	40	JB581260	17	32
JB122003	8	46	JB581271	7	4
JB122016	1	46	JB581272	8	4
JB161002	12	58	JD511010	3	2
JB181220	4	72	JD521002	1	10
JB181221	5	72	JD561004	6	16
JB181239	3	72	JD561011	4	16
JB231206	4	36	JE541008	14	30
JB231206	4	90	JG571024	13	22
JB511011	4	2	JK113008	18	50
JB511015	8	2	JK541214	2	24
JB511019	3	4	JK541214	10	26

Parts Index

Part Number	Figure No.	Page No.	Part Number	Figure No.	Page No.
JN402000	12	42	JW122004	14	58
JP541208	3	26	JW131601	19	56
JV161001	4	60	JW561206	2	18
JV161002	5	60	JW561208	3	18
JV161014	9	58	JZ511020	5	2
JV171001	4	66	JZ511021	1	2
JV181408	9	48	JZ551004	18	14
JV181410	10	48	JZ551204	14	14
JV191001	1	84	JZ551205	13	14
JV351204	5	42	JZ551413	1	28
JV351600	7	40	JZ551415	8	28
JV401600	1	86	JZ561002	7	16
JV401801	7	86	JZ561401	9	18
JV401802	8	86	JZ621001	10	30
JV521003	8	8	KADF0822	11	50
JV541007	2	2	LJA00004	14	22
JV541007	11	20	PF111000	1	44
JV541007	16	22	PF113000	10	50
JV541007	4	26	PF113001	12	50
JV541205	18	24	PF113002	15	50
JV541206	15	22	PF113003	16	50
JV541206	5	26	PF113008	1	90
JV541208	5	24	PF113009	2	90
JV541209	15	24	PF113200	1	50
JV541212	5	26	PF113400	5	44
JV541215	14	24	PF113401	5	44
JV541215	2	26	PF121001	1	62
JV541216	10	20	PF121002	20	62

Parts Index

Part Number	Figure No.	Page No.	Part Number	Figure No.	Page No.
PF121003	21	62	PF351200	6	42
PF121010	5	62	PF401000	1	76
PF122004	4	46	PF401400	2	60
PF131204	23	56	PF401401	3	60
PF131208	22	56	PF401402	3	60
PF131213	1	56	PF401403	5	86
PF141002	7	56	PF402201	3	86
PF151000	1	60	PF402204	3	86
PF161001	2	58	PF501005	1	20
PF161002	1	58	PF501006	1	20
PF161003	6	60	PF511200	1	8
PF161004	8	60	PF531002	4	12
PF161201	1	78	PF541018	7	20
PF161202	3	78	PF541211	1	26
PF161203	7	60	PF551002	1	14
PF161204	2	78	PF551003	8	14
PF161205	9	60	PF551200	6	14
PF171800	4	68	PF551201	5	14
PF171803	6	68	PF551202	2	14
PF231201	5	90	PF551203	10	14
PF231401	7	82	PF551204	11	14
PF231405	2	84	PF551205	12	14
PF231600	10	60	PF551206	9	14
PF231601	11	60	PF561000	1	16
PF351004	2	42	PF561002	5	16
PF351005	1	42	PF561200	1	18
PF351006	2	42	PF571000	1	38
PF351007	1	42	PF571001	5	38

